

Installation, Operation and Maintenance **MANUAL**



SMARTCONNECT G2

v. 0.2

MANUFACTURER:

IRRICONTROL CONTROLE INTELIGENTE DE IRRIGACAO S.A

CNPJ: 26.941.490/0002-03

Rua Eislében Cereja Correa Fonseca, 117 - Lote 01-A Quadra Galpão 02 - Parte A

Distrito Industrial, São João da Boa Vista - São Paulo, Brasil

Zip Code: 13877-776

Phone: +55 (019) 3634-1212

Email: contato@irricontrol.com.br

Website: www.irricontrol.com.br

TECHNICAL SUPPORT:

In case of problems or additional questions, contact Irricontrol Technical Support using the following channels:

Irricontrol Platform: Available on the Google Play Store (Android) and App Store (Apple).

Phone: +55 (019) 2112-9856

Email: suporte@irricontrol.zendesk.com

A dedicated section is also available on the **Irricontrol Knowledge Platform (Zendesk)**, where customers can access the digital version of this manual, additional product information, and possible updates.

Zendesk can be accessed through the following link:

<https://irricontrol.zendesk.com/hc/en-us>

DATE	REVISION	DESCRIPTION	REVISED BY	APPROVED BY
01.2025	00	- Start of the document.	v.santos	I.óboli
05.2025	0.1	- Addition of footer elements. - Restructuring of sections. - Emphasis on the incompatibility of the Injector Pump function.	v.santos	I.óboli
01.2026	0.2	- Update of technical specifications. - Restructuring of topics. - Addition of information about the controller's operation. - Translation of the manual into Spanish.	a.fernandes	I.óboli

CONGRATULATIONS! You have just acquired an IRRICONTROL product!

Our solutions allow the entire irrigation process to occur in a more efficient, sustainable, and controlled way. Enjoy the benefits of smart irrigation.



Share this idea! #ForAGreenWorld 📱 🌱 💧 🌿



NOTES

This document uses notes to organize and highlight critical information related to the operation and maintenance of the equipment. The notes are categorized according to their purpose, as described below:



SUPPLEMENTARY NOTE – Provides additional information that helps in understanding or performing a task but is not essential for the safety or functionality of the equipment.



WARNING NOTE – Draws attention to potential equipment damage or critical details that may impact system performance.



DANGER NOTE – Highlights situations that pose risks to the physical safety or life of the operator. These notes must be strictly followed to prevent serious injury or death.



SCHEDULING NOTE – Specifies recommended time intervals for tasks such as preventive maintenance or operational adjustments.

Pay attention to these notes throughout the manual, as they are designed to enhance understanding and ensure safety and efficiency when using the equipment.

SUMMARY

LIST OF FIGURES.....	9
1. Introduction	13
2. Alerts.....	14
3. Warranty.....	15
4. Technical Data Sheet.....	16
5. Product Presentation	17
6. Product Composition	18
6.1. Digital Controller.....	20
7. Installation	23
7.1. Mechanical Installation.....	23
7.2. Electrical Installation.....	24
7.2.1. Power Supply Cables.....	25
7.2.2. Multiconductor Cables	27
7.2.3. Pressure Switch Cables	29
7.2.4. Pumping Cables	30
7.2.5. Alarm System SAF Cables.....	31
7.2.6. Cabinet Power Up.....	32
8. Parameter Configuration	34
8.1. Cabinet.....	34
8.1.1. KTM 1.....	35
8.1.2. KTM 2.....	36
8.1.3. Power Supply	37
8.2. Digital Controller.....	38
8.2.1. Endgun	39
8.2.2. Sector.....	40
8.2.3. Segments	41
8.2.4. Pressure Configuration	41
8.2.5. Clock	43

8.2.6. Parameters of Pivot.....	44
8.2.7. Pause Time	44
8.2.8. Power Delay	46
8.2.9. Autoreverse.....	46
8.2.10. GPS Coordinates.....	48
8.2.11. Radio	49
8.2.12. Injection Pump	52
8.2.13. Voltage Limits.....	53
8.2.14. Voltage Calibration	54
8.2.15. Operation Time	54
8.2.16. Rainmeter.....	55
8.2.17. Time Range.....	57
8.2.18. Language	57
8.2.19. Error Log.....	58
8.2.20. Pressure Fail Configuration	59
8.2.21. Alignment.....	60
8.2.22. About.....	61
9. Emergency Systems.....	62
10. Testing Procedure.....	63
10.1. ANALOG Mode Testing.....	63
10.2. DIGITAL Mode Testing	64
10.3. EMERGENCY SYSTEM Testing.....	65
11. Equipment Operation.....	67
11.1. Operation - ANALOG Mode.....	67
11.1.1. Operation in Dry Mode - ANALOG	68
11.1.2. Operation in WET Mode - ANALOG	69
11.2. Operation - DIGITAL Mode	71
11.2.1. Operation in Simple Irrigation Mode - DIGITAL	71
11.2.2. Operation in Segment Irrigation Mode - DIGITAL	73
11.2.3. Operation in Schedule Irrigation Mode - DIGITAL.....	75

12. Failures and Possible Causes	77
12.1. Digital controller constantly initializing	77
12.2. Digital controller does not power on.....	78
12.3. Time Mismatch Error	78
12.4. Pivot stopped due to misalignment - CODE 15	78
12.4.1. Realignment procedure	79
12.5. Pivot stopped due to pressure drop - CODE 16.....	79
12.6. Pivot set in dangerous Direction - CODE 17	79
12.7. Pivot stopped due to power failure - CODE 18.....	80
12.8. Pivot stopped due to voltage out of safe range - CODE 19	80
12.9. Pivot stopped due to invalid parameter error - CODE 20.....	80
12.10. Pivot stopped due to unknown error - CODE 21	81
12.11. Pivot stopped due to pump time exceeded - CODE 23	81
12.12. Error when connecting the remote pump - CODE 32	81
13. Additional Information and Precautions	82
13.1. Product Storage	82
13.2. Product Serial Number	82
13.3. Disposal of the Product and/or Components.....	83
13.4. Electrical Power Quality.....	84
13.5. Periodic Maintenance.....	84
13.5.1. Replacement of the CR2032 3V battery	85
13.5.2. Cleaning the Interior of the Equipment.....	86
13.5.3. Checking the Silica Gel.....	86
13.5.4. Checking the Seals	86
13.5.5. Other Irrigation System Maintenance	86
ANNEX 1 – ELECTRICAL DIAGRAM	87

LIST OF FIGURES

Figure 1 - Cabinet Components.....	18
Figure 2 - Controller Commands.....	20
Figure 3 - INFORMATION Function.....	21
Figure 4 - HISTORY Function.....	22
Figure 5 - Mounting of the cabinet brackets to the pivot's central tower.....	23
Figure 6 - Mounting of the cabinet to the pivot's central tower.....	24
Figure 7 - Cover of the cable routing duct.....	25
Figure 8 - Cable gland (PG) for the cabinet power supply cables.....	25
Figure 9 - Terminals for connecting the cabinet power supply.....	26
Figure 10 - Power cable connection to Transformer T1 (wire number 14).....	26
Figure 11 - Cable gland (PG) for the multiconductor cables.....	27
Figure 12 - Terminals for connecting the multiconductor cables.....	27
Figure 13 - Ground wire connection.....	28
Figure 14 - Cable gland (PG) for pressure switch cables.....	29
Figure 15 - Terminals for connecting the pressure switch cables.....	29
Figure 16 - Cable gland (PG) for pumping cable routing.....	30
Figure 17 - Terminals for connecting the pumping cables.....	30
Figure 18 - Cable gland (PG) for SAF cables.....	31
Figure 19 - Terminals for connecting the SAF cables.....	31
Figure 20 - Circuit breakers F1, F2, and F3 - OFF/ON.....	32
Figure 21 - Emergency Button Position for the Cabinet to be TURNED ON.....	32
Figure 22 - Main Switch in the "ON" position.....	33
Figure 23 - KTM 1 Adjustment.....	35
Figure 24 - KTM 2 Adjustment.....	36
Figure 25 - Power Supply Adjustment.....	37
Figure 26 - Display cursor and current/total screen indicator.....	38
Figure 27 - Endgun - ON Mode.....	39
Figure 28 - Endgun - OFF Mode.....	39
Figure 29 - Endgun - ANGLE Mode.....	39

Figure 30 - Sector Parameter for 360° pivots.....	40
Figure 31 - Sector Parameter for pivots operating below 360°.....	40
Figure 32 - Definition of segments.....	41
Figure 33 - Pressure Configuration - ON Mode.....	41
Figure 34 - Pressure Configuration - OFF Mode.....	42
Figure 35 - Pressure Configuration - SENSOR Mode.....	42
Figure 36 - Clock configuration (date and time).	43
Figure 37 - Parameters of Pivot.....	44
Figure 38 - Pause Time - OFF and ON Modes.	45
Figure 39 - Pause Time – Weekdays and Holidays Setting.	45
Figure 40 - Power Delay.....	46
Figure 41 - Autoreverse - OFF Mode.....	46
Figure 42 - Autoreverse - ON Mode.....	47
Figure 43 - Geographical coordinates of the pivot’s central tower.....	48
Figure 44 - Geographic coordinates of the reference point (NORTH REFERENCE: YES/NO). ..	48
Figure 45 - Registration of radios numbers of the irrigation system devices.	49
Figure 46 - Delete characters from the radio number (ID).	49
Figure 47 - Confirm the entered radio number (ID).....	49
Figure 48 - XBee radio used in Irricontrol products.	50
Figure 49 - Screen for initiating signal tests.	50
Figure 50 - Signal testing of the smart irrigation solution devices.....	50
Figure 51 - Signal Test Results.	51
Figure 52 - Injection Pump - OFF and ON Modes.	52
Figure 53 - Voltage Limits - OFF and ON Modes.	53
Figure 54 - Voltage Calibration.....	54
Figure 55 - Operation Time.	54
Figure 56 - Rainmeter - OFF Mode.....	55
Figure 57 - Rainmeter - ON Mode.....	55
Figure 58 - Rainmeter - Daily/Monthly Records.	56
Figure 59 - Rainmeter - Test and Clear All Options.	56
Figure 60 - Time Range.....	57

Figure 61 - Controller Languages.....	57
Figure 62 - Error Log.	58
Figure 63 - Pressure Fail - OFF Mode.....	59
Figure 64 - Pressure Fail - ON Mode.....	59
Figure 65 - Alignment.	60
Figure 66 - Product Information.	61
Figure 67 - Emergency Button Location.....	62
Figure 68 - Return of the Emergency Button to the “NEUTRAL” position.....	62
Figure 69 - Emergency Button Test.	65
Figure 70 - Main Switch Test.....	66
Figure 71 - ANALOG Controls of the Cabinet.....	67
Figure 72 - ANALOG Mode Selection.....	67
Figure 73 - ANALOG Mode Activation Indicator: display off.....	68
Figure 74 - DRY Mode Operation - ANALOG.....	68
Figure 75 - FORWARD/REVERSE Commands in DRY Mode - ANALOG.	68
Figure 76 - START Command in DRY Mode.....	69
Figure 77 - Pivot Movement Stop in DRY Mode - ANALOG.....	69
Figure 78 - WET Mode Operation - ANALOG.....	69
Figure 79 - FORWARD/REVERSE Commands in WET Mode - ANALOG.	70
Figure 80 - START Command in WET Mode.....	70
Figure 81 - Pivot Movement Stop in WET Mode - ANALOG.....	70
Figure 82 - DIGITAL Mode Selection.	71
Figure 83 - Operation in Simple Irrigation Mode - DIGITAL.....	71
Figure 84 - Operation in Segment Irrigation Mode - DIGITAL.....	73
Figure 85 - Operation in Schedule Irrigation Mode - DIGITAL.	75
Figure 86 - Product Serial Number.....	82
Figure 87 - Battery Position in the Controller.	85

1. Introduction

This manual provides the necessary information for the installation, operation, and maintenance of the SmartConnect G2 cabinet, manufactured by Irricontrol. It is essential that all individuals involved in any of these stages carefully study this manual before starting any procedure. Keep it in a safe, known, and accessible location so that the entire team can consult it whenever needed.

All information contained in this manual is based on the most up-to-date data available for Irricontrol's product portfolio at the time of printing. Due to the continuous development of its equipment, the company reserves the right to modify the contents of this manual without prior notice and disclaims any responsibility for consequences arising from such changes. To keep customers informed, the company maintains a section on its knowledge base and on the Irricontrol/Zendesk platform, where updates and other relevant information about the equipment are published.

The images included in this manual are for illustrative purposes only and may differ from the actual equipment. Their inclusion is intended to facilitate the understanding of the equipment and its operation. To ensure clarity, and given the wide range of possibilities, this manual does not cover every conceivable situation related to operation and maintenance. Should further clarification be required, Irricontrol technical support may be contacted.

The content of this document is the intellectual property of Irricontrol. Reproduction or distribution, even in part, is not permitted without express written authorization.

Due to the technical specifications of the equipment, product names and brands from other companies in the irrigation sector may be mentioned. Irricontrol reaffirms its commitment to respecting the intellectual property of each of these companies. Such references are included solely to provide the necessary information for proper installation for our clients and partners.

2. Alerts

The SmartConnect G2 cabinets operate at a voltage range of 440 VAC to 520 VAC. Therefore, it is essential to strictly follow the instructions provided in this manual to avoid serious personal injury and/or equipment damage. It is recommended that this manual remain with the product and be stored in a protected, known, and easily accessible location for operators, technicians, and other individuals involved.

The SmartConnect G2 cabinet is installed on the structures of Bauer pivots and integrated into their electrical and hydraulic systems. Therefore, it is crucial to ensure that all assembly instructions and precautions provided by the pivot manufacturer are strictly followed. Simultaneous consultation of the SmartConnect G2 cabinet manual and the Bauer pivot manual is essential to guarantee the safety and proper operation of the irrigation system.

Due to its high adaptability to different scenarios and applications, the SmartConnect G2 offers several configuration options to customize its operation according to user needs and preferences. However, it is the customer's responsibility to study and define the parameters to be configured and entered into the equipment. If these parameters are incorrectly entered into the cabinet, the irrigation system may operate in an unsafe manner, putting both equipment and personnel at risk.

The reproduction or distribution of this manual, in whole or in part, to third parties is strictly prohibited without prior and express authorization from Irricontrol.



Only authorized personnel must perform maintenance and interventions on the equipment. Following this recommendation is essential to ensure the safety and proper functioning of the system.



Always follow proper safety and operating instructions. Improper handling of the equipment may result in an electrical hazard.



It is the user's responsibility to comply with all safety standards and applicable local regulations during the installation, operation, and maintenance of the equipment.



3. Warranty

Irricontrol offers a warranty for its entire product line, covering manufacturing defects and malfunctions. In such cases, the company is committed to providing full support by performing repairs and/or replacements, either partially or fully, at Irricontrol's discretion.

For the warranty to be valid and enforceable, it is essential that all conditions and rules described and agreed upon in the **WARRANTY TERMS** are fully observed.

We recommend consulting the **PURCHASE AND SALE AGREEMENT** for further details and information regarding duration, coverage, claim procedures, exclusions, and the documentation required to initiate the warranty process.



It is recommended to properly file all documents related to the equipment purchase, such as the INVOICE and WARRANTY TERMS. This will expedite any warranty service process.



The information contained in this manual does not replace, add to, or modify any agreement established by the PURCHASE AND SALE AGREEMENT and/or WARRANTY TERMS.



Modifying or replacing any components of the equipment may cause malfunction and affect the product warranty. Therefore, it is always recommended to consult the manufacturer or an authorized representative before carrying out such interventions.

4. Technical Data Sheet

DESCRIPTION	INFORMATION	
Product Name	SmartConnect G2	
Manufacturer Code (SKU) ¹	2787, 2890, 4239, 7083	
Short Description	Control cabinet for automation of Bauer center pivot irrigation systems.	
Supply Voltage ²	480 - 520 VAC (3F + PE)	
Control Voltage	220 VAC	
Maximum Current	32 A at 480 V	
Rated Power	-	
Rated Current	Depending on the pivot design.	
Frequency	50/60 Hz	
Operating Temperature	-5 °C to +40 °C	
Protection Rating (IP)	IP65	
Dimensions (H × W × D)	800 × 600 × 294 mm	
Weight	~ 93 kg	
Materials and Finish	Carbon steel body with electrostatic paint.	
Connector Type	Terminal Block and WAGO connectors.	
Communication ¹	Radio	DIGI XBEE-PRO 900HP (XBP9B-DMST-012)
		DIGI XBEE SX 868 (XB8X-DMUS-001)
		DIGI XBEE XR 868 (XB-8XR-DMUT-101)
	4G	
Installation Environment	External	
Standards Complied With	ABNT NBR IEC 61439	
Included Accessories	SmartConnect G2 cabinet, Support Kit, Mounting Kit, and Manual.	
Optional Accessories	Pressure Sensor (Riser Tube)	
Packaging	Wooden box (950 × 805 × 350 mm)	
Manufacturer / Technical Contact	Irricontrol Controle Inteligente de Irrigação LTDA / Luiz Roque	

¹ Depending on the purchased version and the installation region.

² According to the connection on the primary transformer (T1).



5. Product Presentation

The SmartConnect G2 cabinet is a device designed to control Bauer central pivot irrigation systems, fully integrated with other Irricontrol products and solutions. Its functionalities enable automated control of irrigation systems, contributing to process optimization and making them more precise, controlled, and efficient.

Additionally, it provides access to relevant information that assists producers in the decision-making process. This information includes data on pivot operation, weather conditions, and other parameters relevant to the customer.

By optimizing the use of water and other resources, it also contributes to energy efficiency and cost savings. Moreover, intelligent water resource management can lead to tax incentives and certifications, promoting social and environmental responsibility.

The SmartConnect G2 cabinet also plays a key role in protecting the electrical and mechanical components of the irrigation system. In addition to featuring safety devices that monitor the system and issue alerts in the event of risk conditions, such as excessive pressure variation, critical misalignment, jamming, and component damage from lightning strikes, Irricontrol cabinets are equipped with robust firmware logic that triggers alerts and immediately shuts down the system in case of failure, making the irrigation process safer.

6. Product Composition

The SmartConnect G2 cabinet is a high-tech device that integrates a variety of mechanical, electrical, and electronic components. These elements work in harmony to ensure precise and efficient control of the irrigation system, delivering reliable and high-performance operation.

Figure 1 illustrates the layout of the product components, followed by a table describing each item.

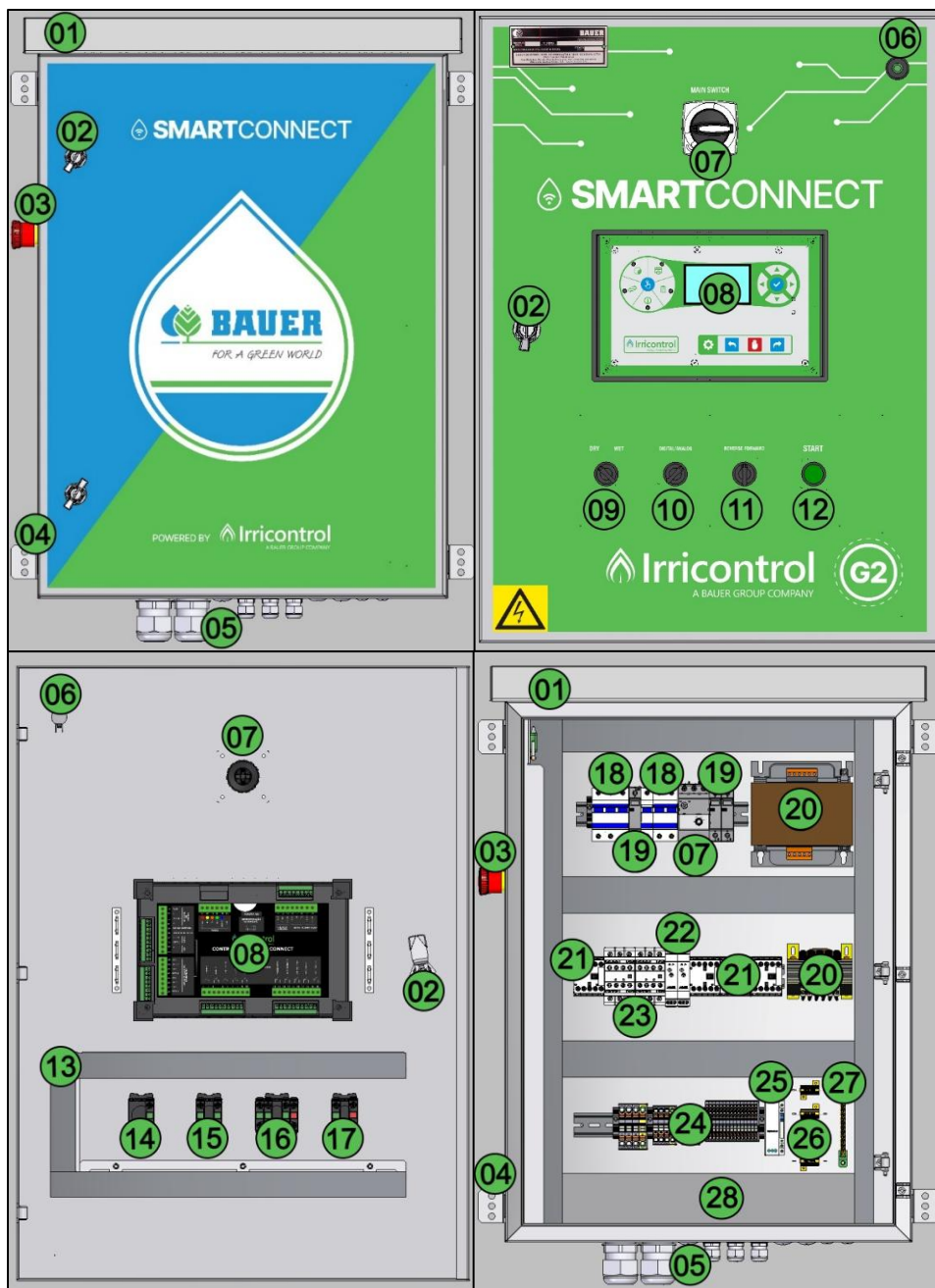

Figure 1 - Cabinet Components.



ITEM	DESCRIPTION
01	GALVANIZED STEEL CABINET
02	CABINET LOCKS
03	EMERGENCY BUTTON
04	FIXING HANDLE
05	CABLE GLANDS
06	LED SWITCH
07	SELECTOR SWITCH – MAIN SWITCH
08	CONTROLLER
09	SELECTOR SWITCH – DRY/WET
10	SELECTOR SWITCH – DIGITAL/ANALOG
11	SELECTOR SWITCH – REVERSE/STOP/FORWARD
12	ANALOG BUTTON – START
13	CABLE PASSAGE TRAYS – INNER DOOR
14	CONTACT BLOCK – START BUTTON
15	CONTACT BLOCK – REVERSE/STOP/FORWARD
16	CONTACT BLOCK – DIGITAL/ANALOG
17	CONTACT BLOCK – DRY/WET
18	CIRCUIT BREAKER
19	SURGE PROTECTION DEVICE
20	TRANSFORMER
21	CONTROL CONTACTORS
22	TIMER RELAYS
23	POWER CONTACTORS
24	TERMINAL BLOCK
25	POWER SUPPLY
26	RESISTORS
27	GROUNDING BAR
28	CABLE PASSAGE TRAYS – CABINET

6.1. Digital Controller

The Digital Controller integrated into SmartConnect G2 plays a key role in information management and in executing commands within the SmartConnect G2 cabinet.

Using the buttons on its interface, the controller can be configured, operating modes can be customized, and pivot commands can be executed. Configuration and operation status information is displayed both on the controller screen and on the Irricontrol platform (when the pivot is operated in DIGITAL mode).

The front of the controller consists of several elements with different functions. Figure 2 identifies these elements, and their descriptions are presented below.

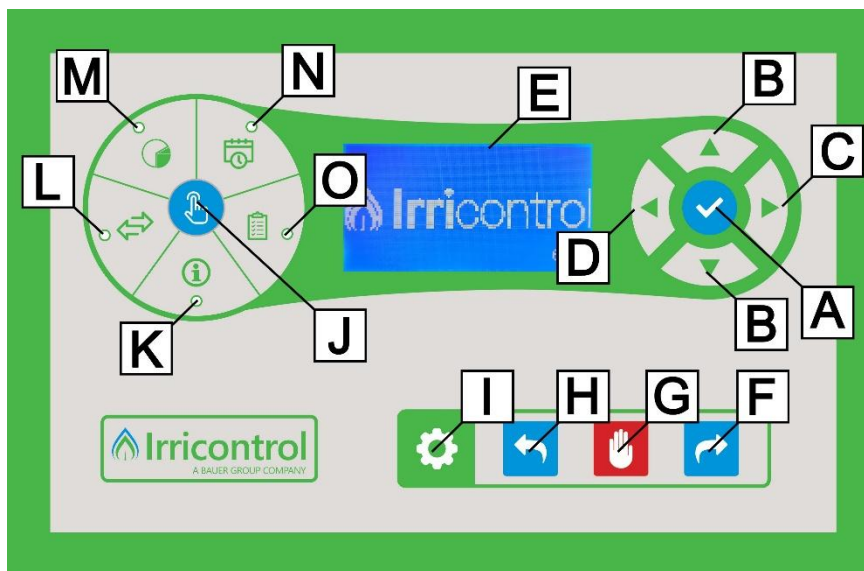

Figure 2 - Controller Commands.

- A. **EDIT/CONFIRM** – Used to edit or confirm parameters/actions.
- B. **UP/DOWN ARROWS** – Used to navigate through the options in the OPERATIONS MENU (J) and the SETTINGS MENU (I) or change the value of the selected parameter.
- C. **RIGHT ARROW** – Used to access options in the OPERATIONS MENU (J) and the SETTINGS MENU (I).
- D. **LEFT ARROW** – Used to return to the previous section.
- E. **DISPLAY** – Controller display screen.
- F. **FORWARD COMMAND** – Used to activate the FORWARD command of the pivot.
- G. **STOP COMMAND** – Used to activate the STOP command of the pivot.



- H. **REVERSE COMMAND** – Used to activate the REVERSE command of the pivot.
- I. **SETTINGS/RESET** – Used to access the controller settings or restore factory defaults.
- SINGLE CLICK – Access the controller SETTINGS.
 - LONG PRESS – RESET the controller and restore factory settings. When this option is selected, a confirmation message is displayed on the screen.
- J. **OPERATION MENU** – Provides access to the pivot’s operating modes, information, and history, located at positions K, L, M, N, and O. The selected function is indicated by the corresponding illuminated LED. To navigate through the options, press button J until the desired function is reached.
- K. **INFORMATIONS** – If this function is selected, the LED at position K lights up, and pivot status information will be displayed on the screen.

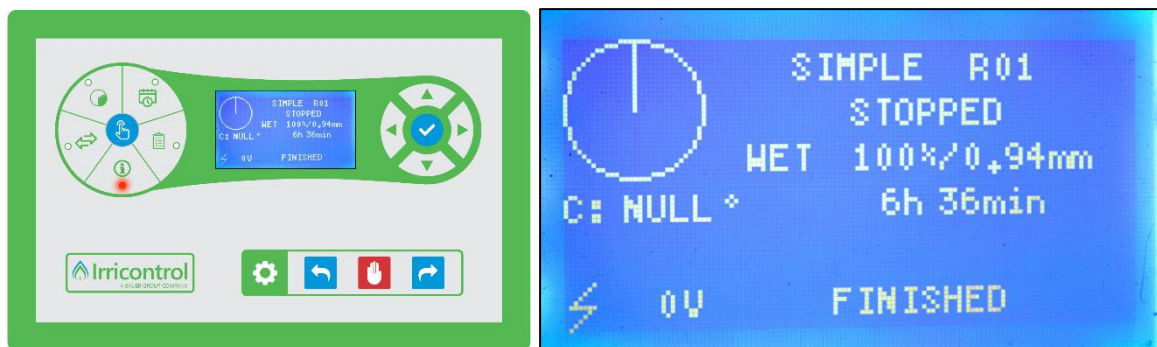

Figure 3 - INFORMATION Function.

- L. **SIMPLE IRRIGATION MODE** – If this function is selected, the LED at position L lights up. In this mode, it is possible to set the operating mode, percentage timer (pivot operating speed), precipitation rate, operation start time, and the pivot stop mode.
- M. **SEGMENTS IRRIGATION MODE** – If this function is selected, the LED at position M lights up. In this mode, the irrigation area can be divided into up to 9 segments, each with customizable settings.
- N. **SCHEDULED IRRIGATION MODE** – If this function is selected, the LED at position N lights up. In this mode, pivot operation can be scheduled.

- O. **HISTORIC** – If this function is selected, the LED at position O lights up, and the entire historic of commands sent to the equipment will be displayed on the screen.

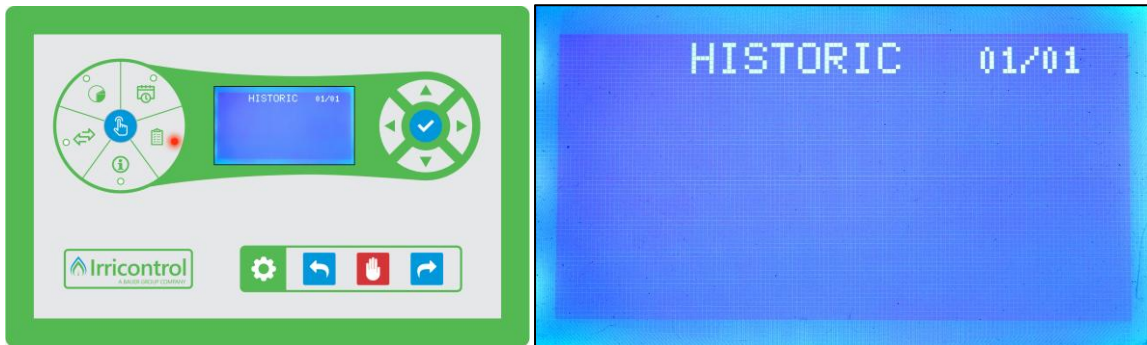

Figure 4 - HISTORY Function.

7. Installation

This section provides a detailed description of the procedures required for the mechanical and electrical installation of the equipment, including proper positioning, correct electrical connections, and the necessary precautions to prevent accidents and damage during the installation process.

7.1. Mechanical Installation

To ensure the equipment is properly installed and ready to operate as intended, the mechanical installation must be carried out as detailed below.



Tighten the fasteners with enough torque to prevent any play or loosening.



This activity must be performed carefully to prevent accidents that may cause harm to personnel involved in the operation and damage to the equipment.

- A. Install the GLV Cabinet Mounting Brackets (5509 - Bauer code) on the pivot's central tower, following the instructions provided in the Bauer Pivot manual.



Figure 5 - Mounting of the cabinet brackets to the pivot's central tower.

- A. Position the cabinet on the bracket and secure it using the four mounting points on the cabinet.

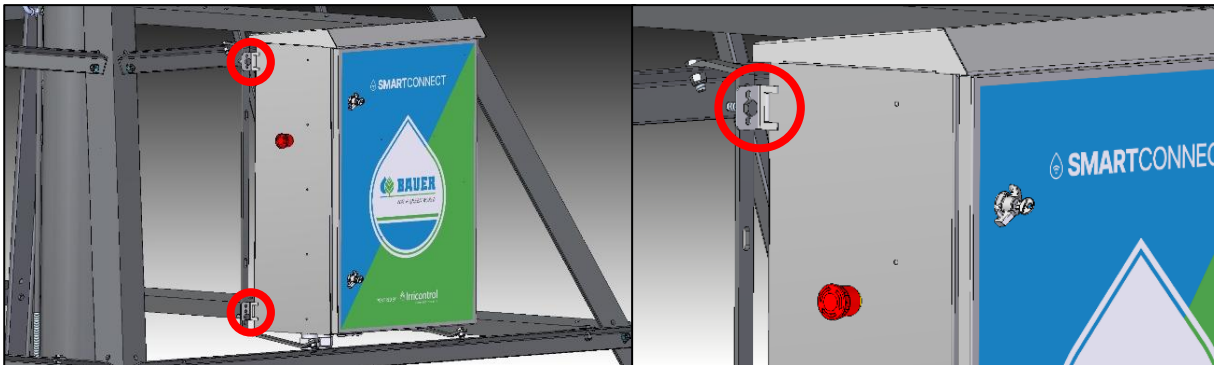

Figure 6 - Mounting of the cabinet to the pivot's central tower.

7.2. Electrical Installation

The electrical installation of the SmartConnect G2 cabinet can be divided into:

- Connection of the power supply cables.
- Connection of the multiconductor cables.
- Connection of the pressure switch cables
- Connection of the pumping cables.
- Connection of the Alarm System SAF cables.
- Cabinet power-up.



Ensure proper execution of the electrical connections to prevent electrical intermittency and/or equipment malfunction.



Before starting the connections, remove the cover of the lower cable duct located inside the inner door of the cabinet to allow the cables to pass through the cable glands (PGs) on the cabinet. After completing the installation, close the duct again.

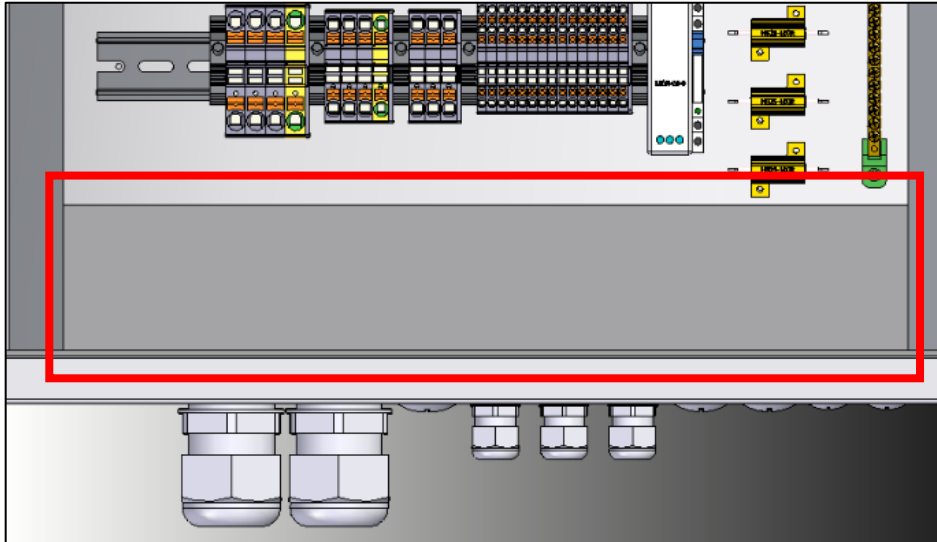

Figure 7 - Cover of the cable routing duct.

7.2.1. Power Supply Cables

The cabinet is powered through a 4-wire cable, consisting of 3 phases (P) and 1 ground (PE). The energy supplied to the cabinet through this cable is distributed to the other electrical devices along the overhead structure of the Bauer pivot.



Due to the risks involved and to ensure the safety of personnel, the activity must be performed with the cables DE-ENERGIZED.

- A. Pass the cable through the PG29 cable gland, shown in Figure 8.

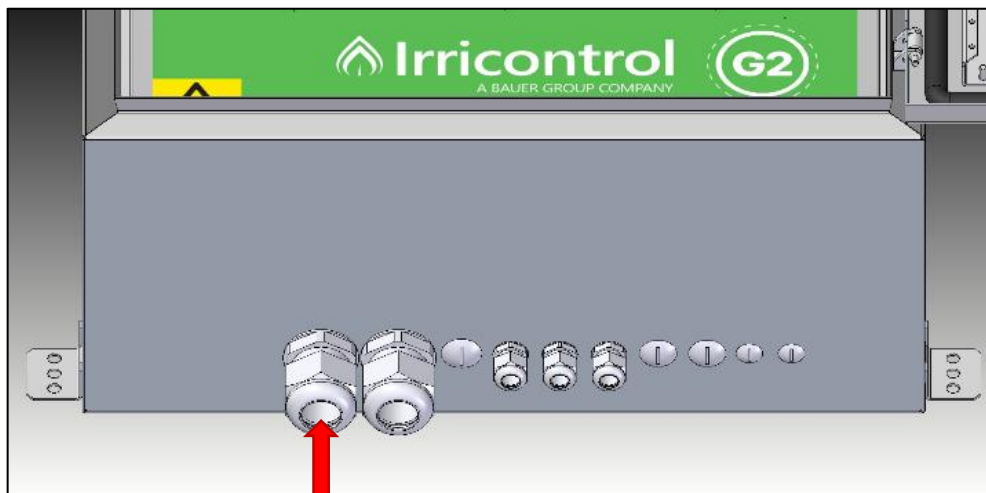

Figure 8 - Cable gland (PG) for the cabinet power supply cables.



- B. Connect the cable wires to the power and ground terminals located in the lower duct (A to D), according to the following arrangement.

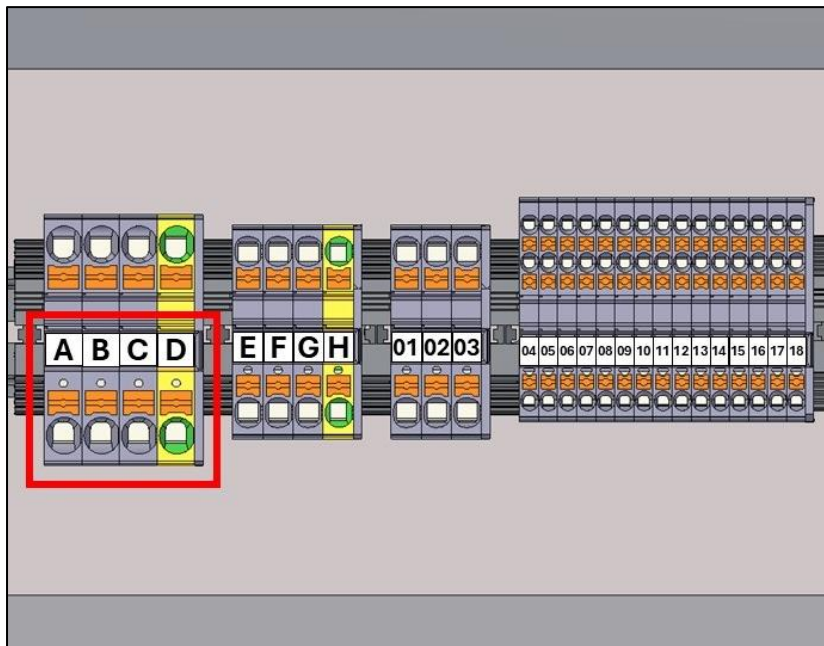

Figure 9 - Terminals for connecting the cabinet power supply.

TERMINAL	FUNCTION
A	Phase
B	Phase
C	Phase
D	Ground

- C. Strip the insulation from wire number 14 and connect it to Transformer T1 according to the local voltage:

LOCAL VOLTAGE	POSITION ON TRANSFORMER
440 VAC	PRI2
460 VAC	PRI3
480 VAC	PRI4
500 VAC	PRI5
520 VAC	PRI6

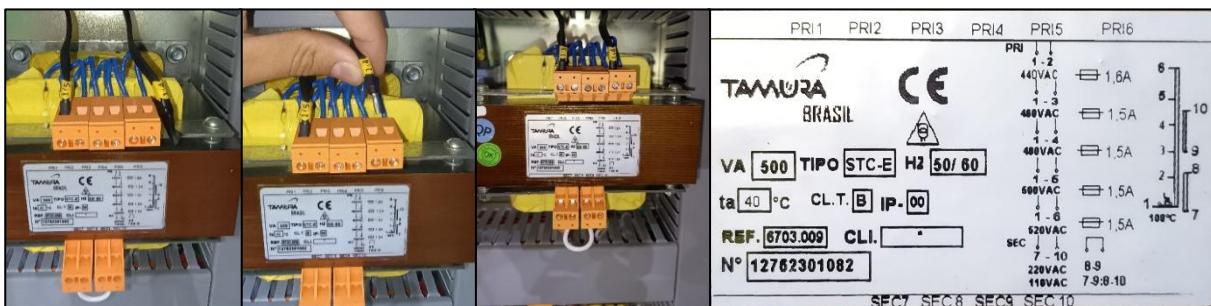

Figure 10 - Power cable connection to Transformer T1 (wire number 14).



7.2.2. Multiconductor Cables

The transmission of command information from the cabinet to the rest of the irrigation system (motors, pumps, safety devices, etc.) is carried out through 11 multiconductor cables. These cables exit the pivot's slip ring and must enter the cabinet.

- A. Pass the multiconductor cables through the PG29 cable gland, shown in Figure 11.

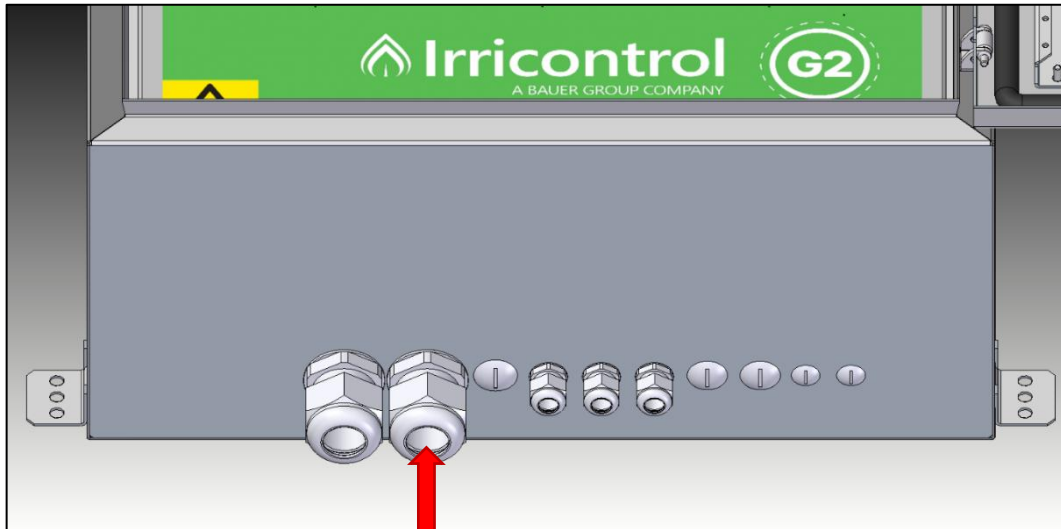

Figure 11 - Cable gland (PG) for the multiconductor cables.

- B. Connect all cable wires, except the green one, to terminals 1 through 10 located in the lower duct, according to the following arrangement.

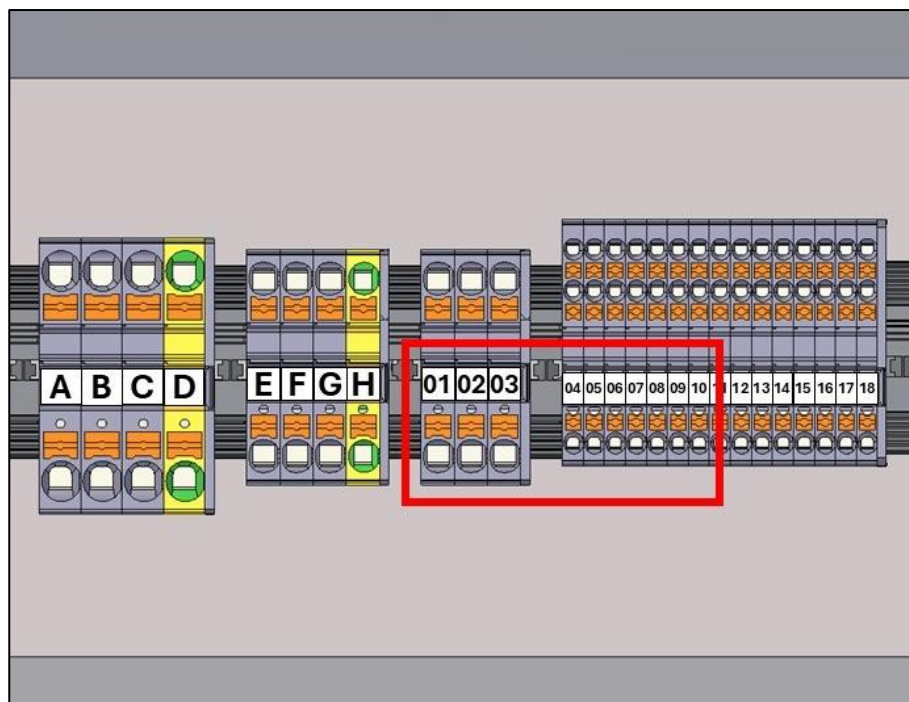

Figure 12 - Terminals for connecting the multiconductor cables.

TERMINAL	WIRE COLOR	FUNCTION
01	Blue	Motors
02	Black	Motors
03	Brown	Motors
04	Pink	Neutral
05	Gray	Forward
06	Red	Reverse
07	White	Safety Output
08	Purple	Safety Input
09	Blue	Last Tower
10	Orange	End Gun

- C. Connect the green conductor (ground wire) to the grounding bar located at the lower right of the cabinet, as shown in Figure 13.

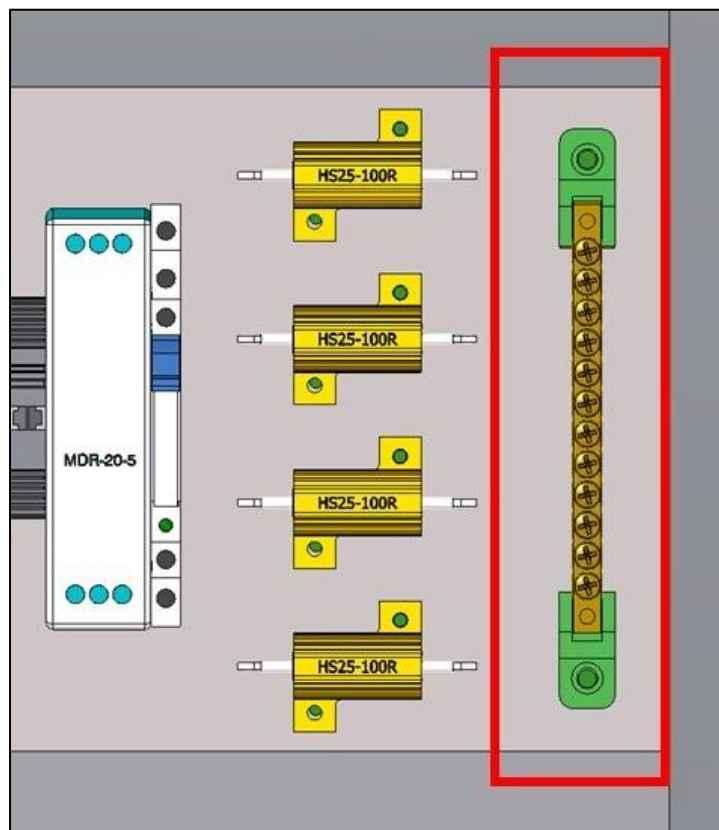

Figure 13 - Ground wire connection.

7.2.3. Pressure Switch Cables

- A. Pass the pressure switch cables through the PG13.5 cable gland, shown in Figure 14.

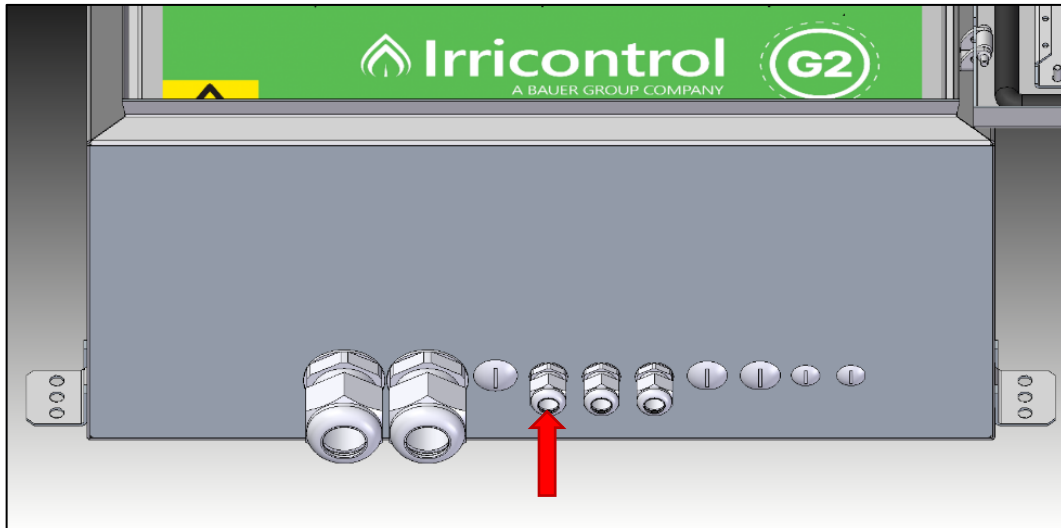

Figure 14 - Cable gland (PG) for pressure switch cables.

- B. Connect the pressure switch cables to terminals 11 and 12 located in the lower duct, according to the following arrangement.

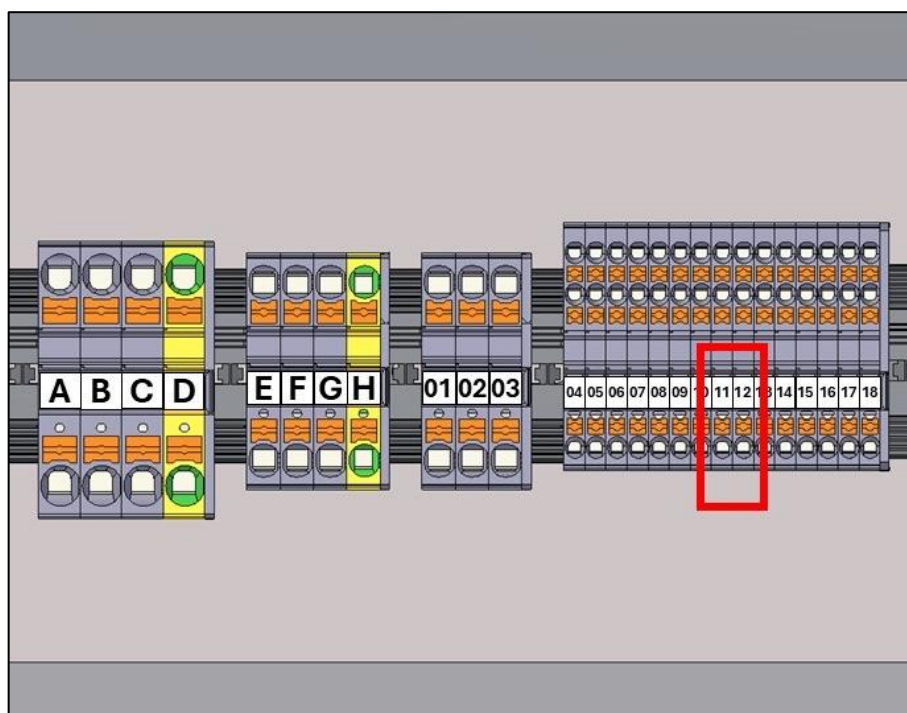

Figure 15 - Terminals for connecting the pressure switch cables.

TERMINAL	FUNCTION
11	Pressure Switch
12	Pressure Switch

7.2.4. Pumping Cables

- A. Pass the pumping cables through the PG13.5 cable gland, shown in Figure 16.

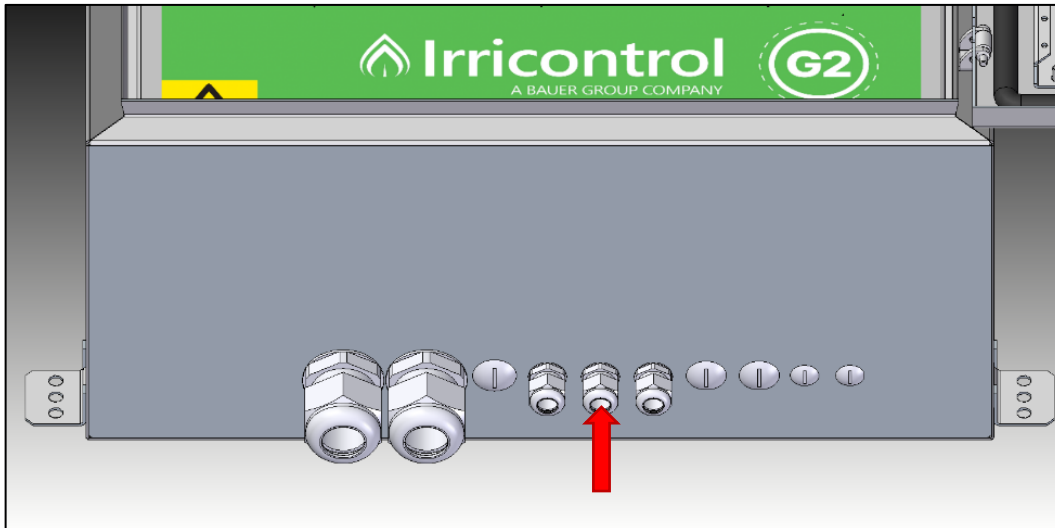

Figure 16 - Cable gland (PG) for pumping cable routing.

- B. Connect the pumping cables to terminals 13 and 14 located in the lower duct, according to the following arrangement.

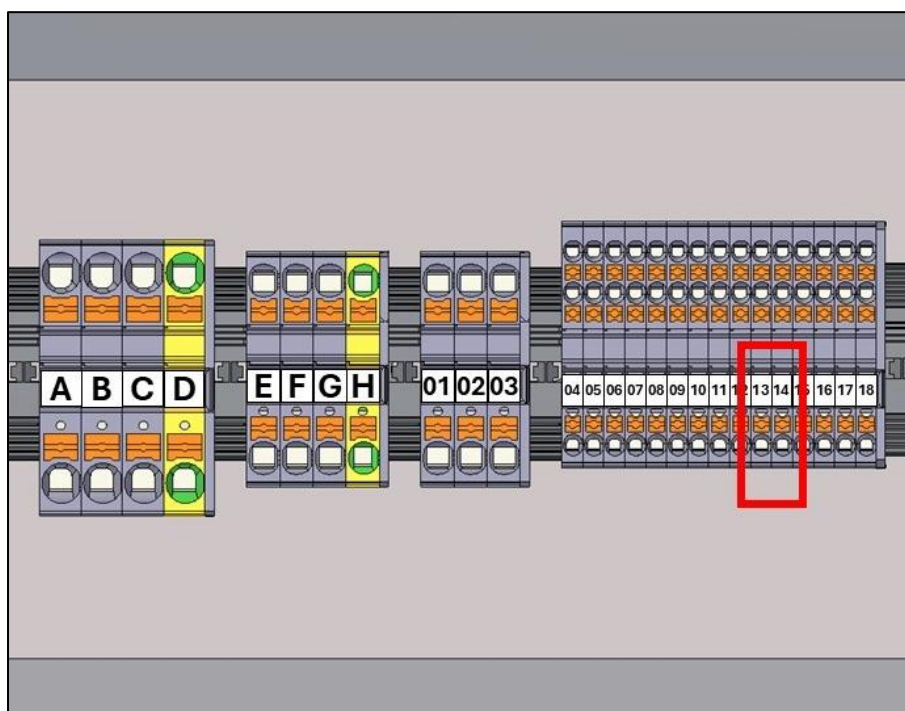

Figure 17 - Terminals for connecting the pumping cables.

TERMINAL	FUNCTION
13	Pumping
14	Pumping



7.2.5. Alarm System SAF Cables

- A. If the SAF is purchased, pass its cables through the PG13.5 cable gland, shown in Figure 18.

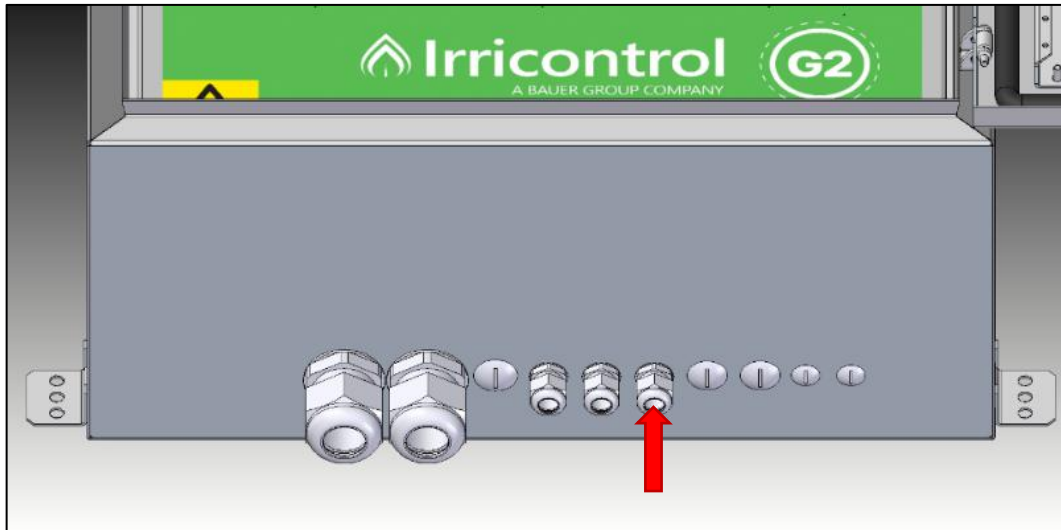

Figure 18 - Cable gland (PG) for SAF cables.

- B. Connect the SAF cables to terminals 15 through 18 located in the lower duct, according to the equipment manual instructions.

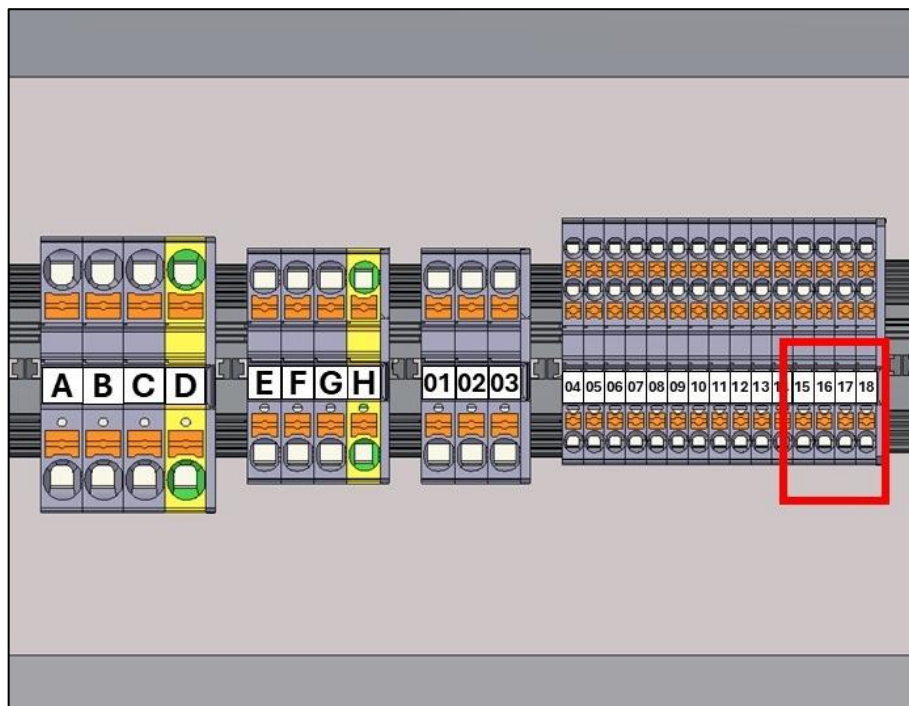

Figure 19 - Terminals for connecting the SAF cables.

7.2.6. Cabinet Power Up

The SmartConnect G2 cabinet can be powered on after all the electrical connections described above have been completed. To do so:

- A. Turn on circuit breakers F1, F2, and F3 located at the upper left of the cabinet.

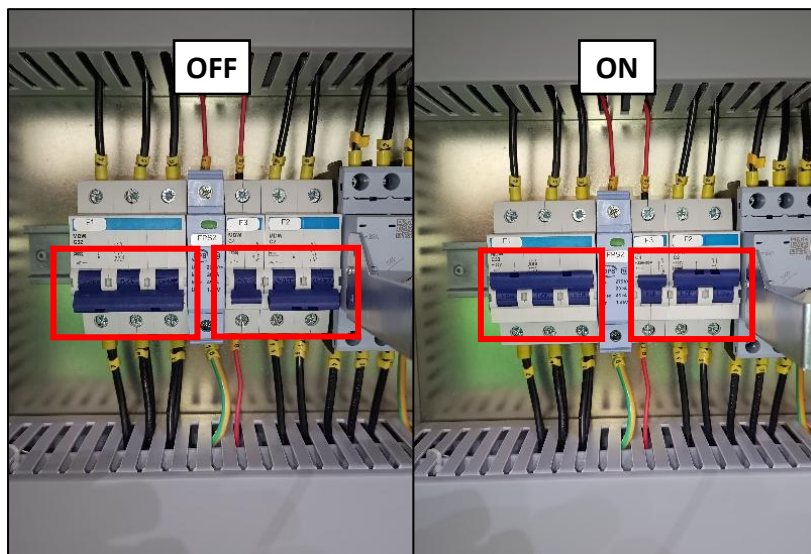

Figure 20 - Circuit breakers F1, F2, and F3 - OFF/ON.

- B. Ensure the Emergency Button is in the “NEUTRAL” position. If not, turn it as shown in Figure 21.



Figure 21 - Emergency Button Position for the Cabinet to be TURNED ON.



- C. Close the cabinet's inner door and turn the Main Switch 90° to the right, as shown in Figure 22.

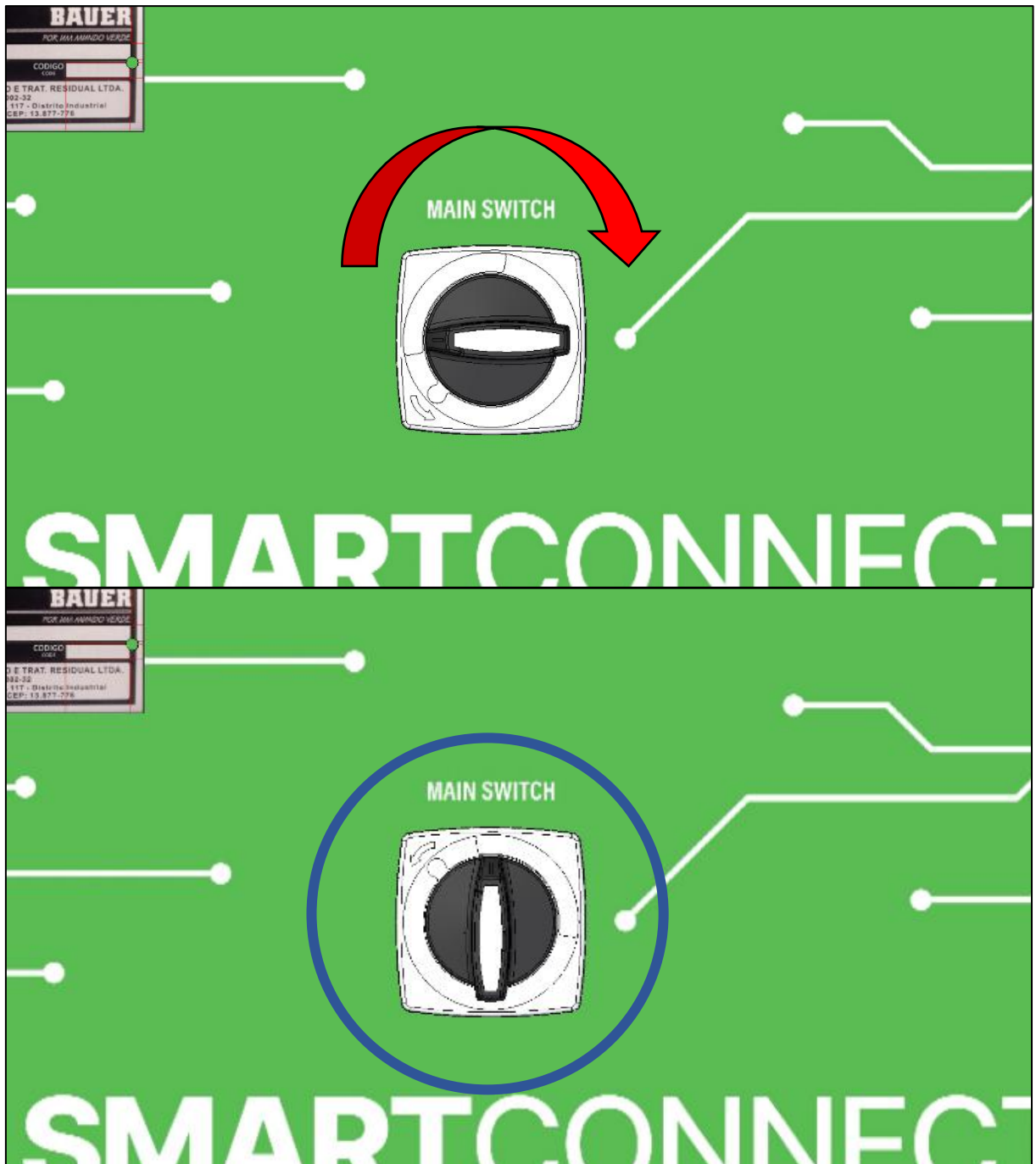

Figure 22 - Main Switch in the "ON" position.

8. Parameter Configuration

The SmartConnect G2 cabinets come pre-configured with factory default parameters that ensure the minimum required functionality for quality testing and installation. However, it is crucial that an authorized professional adjusts these parameters according to the specific requirements of the operating environment and the preferences of the client and/or responsible technician. These adjustments are essential to guarantee optimal irrigation system performance and must be made before the equipment is operated for the first time after installation.

Parameterization can be performed on-site, using certain cabinet components and the digital controller, as described in the following sections, or remotely via the Irricontrol platform.

8.1. Cabinet

The adjustable components of the SmartConnect G2 cabinet are the KT1 time relay (30 minutes), the KTM 2 time relay (10 seconds) and the power supply, which can be seen in Figure 1, item **6. Product Composition**.



The KTM 1 and KTM 3 will only affect the equipment operation if it is set to ANALOG mode (see topic **11.1. Operation - ANALOG Mode**).



8.1.1. KTM 1

The KTM 1 relay is responsible for keeping the pivot paused for a set period, according to the time needed to pressurize the system. This ensures uniform water distribution throughout the entire movement of the equipment.

To adjust it, use a screwdriver/Phillips to rotate the setting clockwise or counterclockwise. The values are indicated on the device itself — from 0 to 30 minutes.

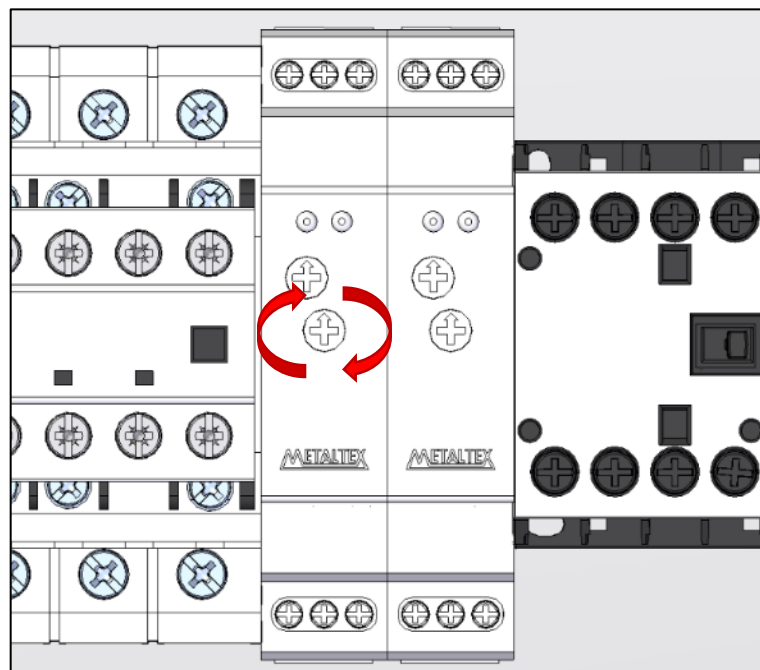

Figure 23 - KTM 1 Adjustment.



The KTM 1 relay is set to 6 minutes at Irricontrol for testing purposes. However, in the field, it should be configured according to the specific time required for the pivot's movement to start after the equipment pressurization.

8.1.2. KTM 2

The KTM 2 time relay is responsible for ignoring the safety signal at the start of operation for a set period.

To adjust it, use a screwdriver/Phillips to rotate the setting clockwise or counterclockwise. The values are indicated on the device itself — from 0 to 10 seconds.

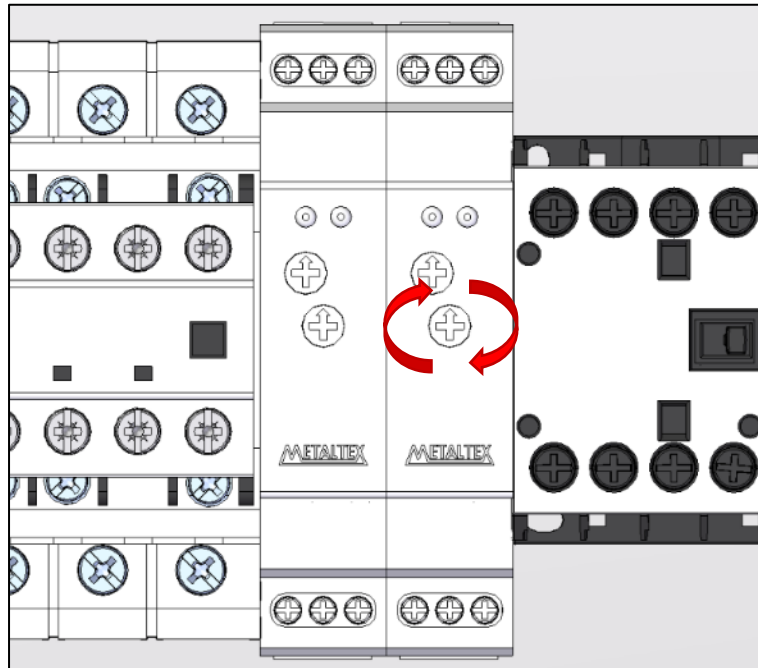

Figure 24 - KTM 2 Adjustment.



The KTM 2 is set to 6 seconds at Irricontrol for testing purposes, and this value should be maintained for field operation. It is recommended to visually verify and adjust it if it is not set to 6 seconds.

8.1.3. Power Supply

The power supply output voltage must be 13 V DC, a value that should be verified using a multimeter. If the measurement shows a different value, use a screwdriver to adjust the voltage, as shown in Figure 25.

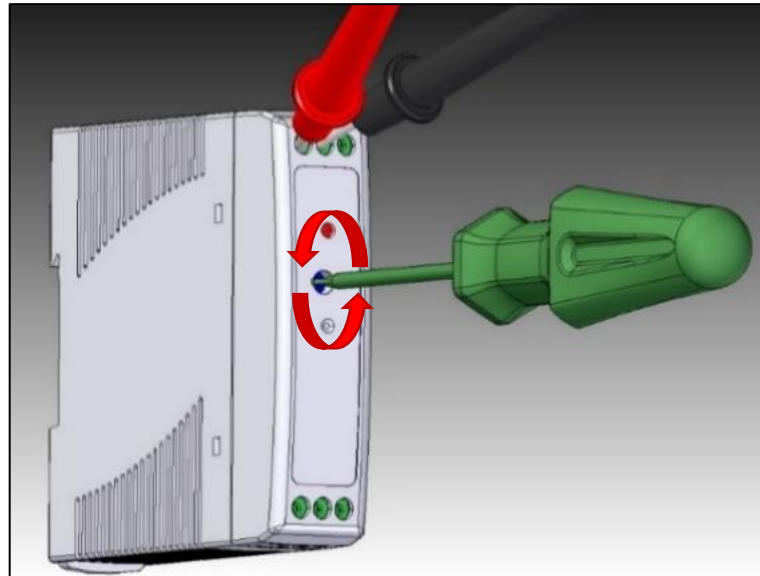

Figure 25 - Power Supply Adjustment.



Measure the power supply voltage while performing the calibration, using a multimeter.

8.2. Digital Controller

The digital controller of the SmartConnect G2 cabinet must be configured according to the customer's preferences and the specific requirements of the installation site.

On the controller display, the cursor position is indicated by an arrow on the left side of the screen. In the top right corner, the current page number and the total number of available pages in the accessed section are displayed. Figure 26 highlights this information.

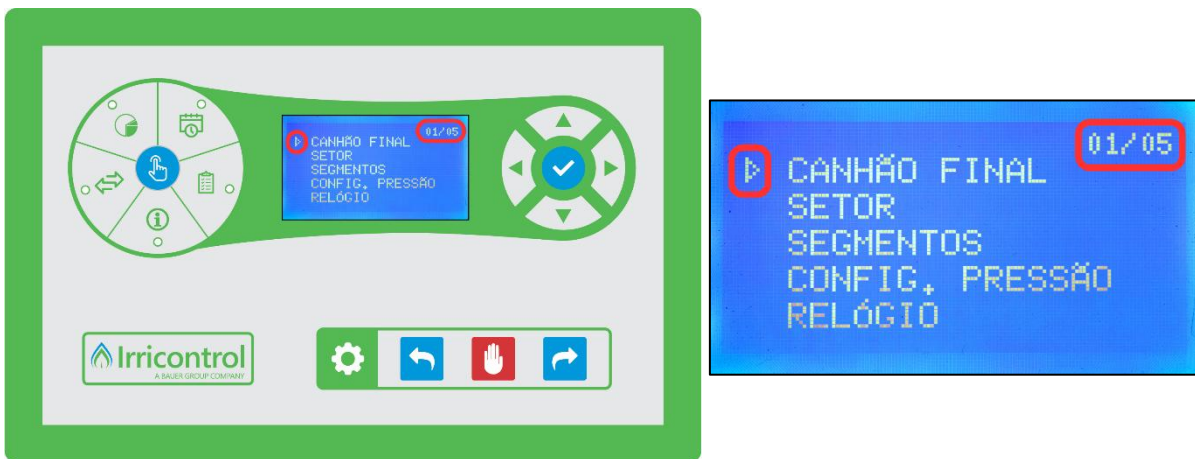

Figure 26 - Display cursor and current/total screen indicator.

To configure the controller, access the SETTINGS and select the parameter according to your needs and/or preferences.



Whenever any local condition is changed or the equipment remains out of operation for extended periods (between crop seasons), it is recommended that the parameters be reviewed.



8.2.1. Endgun

The ENDGUN option allows setting the behavior of the endgun during operation, which can be:

- A. ON – The endgun remains continuously operating while the pivot is in operation.

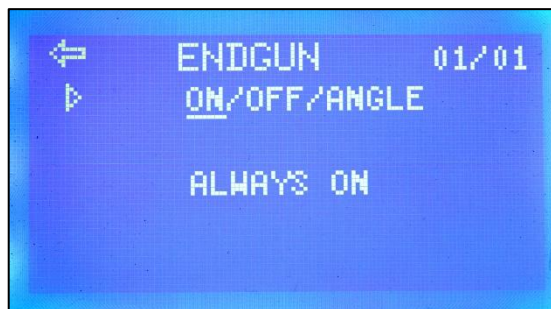

Figure 27 - Endgun - ON Mode.

- B. OFF – The endgun remains off during the pivot operation.

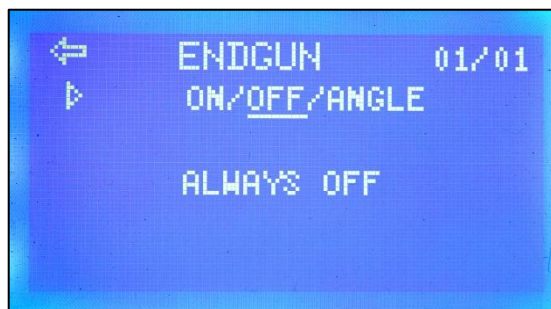

Figure 28 - Endgun - OFF Mode.

- C. ANGLE – The endgun is activated only at angle intervals (up to 10 intervals).



Figure 29 - Endgun - ANGLE Mode.

8.2.2. Sector

The SECTOR option allows the definition of the area in which the pivot will move, based on a starting angle (START field) and an ending angle (END field).

For example, a pivot that can complete a full rotation during its operation (favorable terrain, absence of obstacles, among others) has the SECTOR option set from 0° to 360°.



Figure 30 - Sector Parameter for 360° pivots.

In the case of a pivot installed on an area with movement limitations (uneven terrain, presence of obstacles, among others), it is necessary to set a sector end less than 360° (for example, 270°).



Figure 31 - Sector Parameter for pivots operating below 360°.



8.2.3. Segments

The SEGMENTS option allows the division of the pivot's operating area into separate portions. It is possible to divide the irrigated area into up to 9 segments and configure different precipitation rates for each.

For example, Figure 32 shows a simulation of an operation with three segments:



Figure 32 - Definition of segments.

8.2.4. Pressure Configuration

The PRESSURE CONFIGURATION option allows defining and configuring the equipment used to measure the pivot's pressure: pressure switch or pressure sensor.



The pressure sensors compatible with the Irricontrol solution are of the 4–20 mA type.

There are three possible modes for this option:

- A. ON – The pressure check is performed by the PRESSURE SWITCH located on the pivot's central tower. This device is configured with a minimum pressure range to ensure the necessary conditions for the satisfactory operation of the pivot.



Figure 33 - Pressure Configuration - ON Mode.

In this mode, it is necessary to define PRESSURE TIMEOUT, PRESSURE DELAY and UNSTABLE TIME:

- PRESSURE TIMEOUT – Maximum pressurization time for the pivot.
 - PRESSURE DELAY – Time the pivot must remain stationary after pressure is detected by the pressure switch, following the FORWARD/REVERSE command. Its purpose is to ensure the entire system reaches the correct pressure, guaranteeing uniform irrigation.
 - UNSTABLE TIME – Time the pivot can continue operating when pressure detected is below the level defined by the pressure switch.
- B. OFF – The PRESSURE SENSOR and PRESSURE SWITCH remain disabled, meaning no pressure measurement is performed. Thus, when the FORWARD/REVERSE command is sent, the pivot starts moving immediately, regardless of the pressure in the pivot’s piping.



Figure 34 - Pressure Configuration - OFF Mode.

- C. SENSOR – The pressure check is performed by the PRESSURE SENSOR located on the pivot’s central tower. If the measured pressure is outside the defined maximum and minimum limits, the pivot is stopped, and alert messages are shown on the controller’s display and on the Irricontrol Platform.

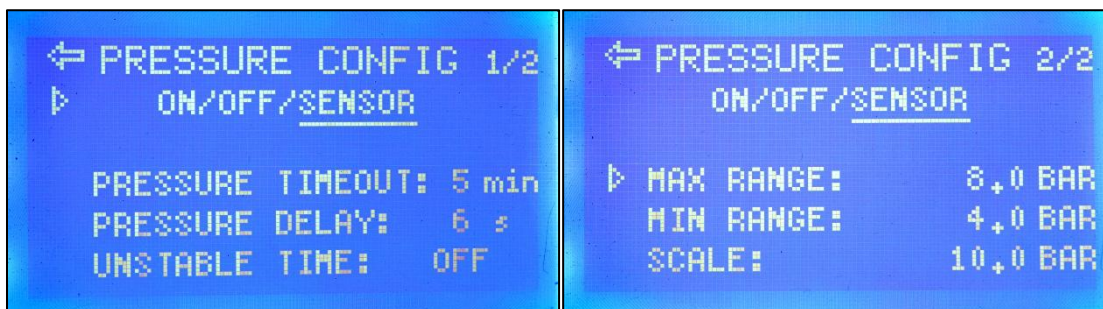

Figure 35 - Pressure Configuration - SENSOR Mode.



In this mode, it is necessary to define PRESSURE TIMEOUT, PRESSURE DELAY, UNSTABLE TIME, MAX RANGE, MIN RANGE and SCALE:

- PRESSURE TIMEOUT – Maximum pressurization time for the pivot.
- PRESSURE DELAY – Time the pivot must remain stationary after pressure is detected by the pressure sensor, following the FORWARD/REVERSE command. Its purpose is to ensure the entire system reaches the correct pressure, guaranteeing uniform irrigation.
- UNSTABLE TIME – Time the pivot can continue operating when pressure detected is below the level defined by the pressure sensor.
- MAX RANGE – Maximum acceptable pressure value before the pivot is stopped and alerts are displayed on the controller display and platform.
- MIN RANGE – Minimum acceptable pressure value before the pivot is stopped and alerts are displayed on the controller display and platform.
- SCALE – Defined according to the sensor range installed on the pivot (commonly, pivots use sensors up to 10 BAR).

8.2.5. Clock

The CLOCK option allows adjustment of the controller’s date and time according to the local date and time. This adjustment is important to avoid failures in scheduled operations and conflicts between the platform’s time and the SmartConnect G2 cabinet’s time.

 The controller does not automatically update the time. Therefore, the user is responsible for adjusting the clock as needed, including at the start and end of daylight saving time.

Figure 36 illustrates the controller screen where this adjustment is made.



Figure 36 - Clock configuration (date and time).

If the controller battery – CR2032 – is removed or runs out of charge, the DATE/TIME settings will be reset, and the display will show an error message - “WARNING WRONG CLOCK”. After reinstalling or replacing the battery, it is necessary to reconfigure the device’s date and time.

8.2.6. Parameters of Pivot

In the PARAMETERS field, the information must be filled in according to the technical specifications provided by the pivot manufacturer and local data.

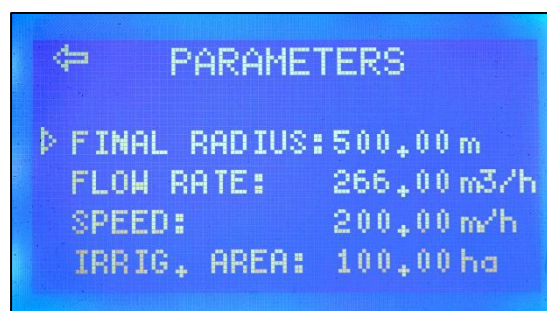

Figure 37 - Parameters of Pivot.

This information is essential for feeding the irrigation table, allowing data related to the pivot's operation to be compiled and accessed when needed, thus facilitating operation management and control.

8.2.7. Pause Time

The PAUSE TIME option allows defining the time interval considered as peak hours. During this period, the pivot operation is automatically stopped and then resumed automatically at the end of the interval.

Peak hour is a mechanism used by electric companies to designate a period when the tariff is higher due to increased consumption. By defining time slots for the pivot to remain inactive during peak hours, producers can minimize their electricity costs. Consult the electricity provider serving your area for more information on this subject.

This parameter can be set to ON or OFF.



Figure 38 - Pause Time - OFF and ON Modes.

- A. OFF – The pivot operates normally regardless of the time.
- B. ON – The pivot operation takes peak hours into account. In this mode, it is necessary to define:
 - START/END – Start and end times of the period. It is recommended to consult the local electric utility company to determine the designated “peak hours” in the region where the pivot will be installed.
 - WEEKDAYS – Days of the week when the schedule should be applied. In some regions, weekends and holidays are exempt from the special tariff.
 - HOLIDAYS – Dates of holidays, which should also be excluded from the schedule.

Figure 39 shows the controller interface where this information is entered:

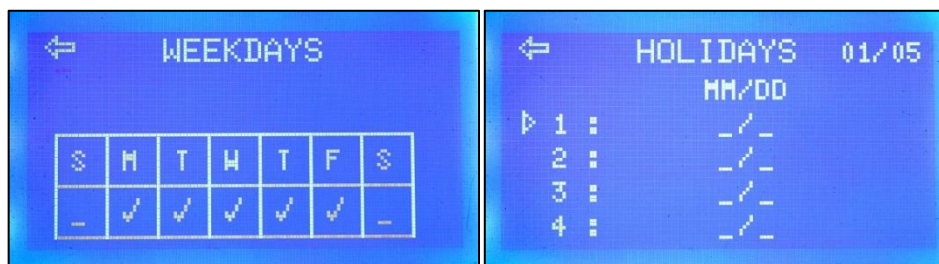

Figure 39 - Pause Time – Weekdays and Holidays Setting.



It is recommended to always consult the supply contract and/or the regulations of the local electric utility to verify the applicable tariff periods and the rules related to holidays.



National holidays can be automatically imported by the Irricontrol Platform and sent to the controller through a configuration upload. Other holidays, such as state and municipal ones, must be added manually via the controller or the platform.



The control and verification of the holidays configured on the Irricontrol Platform are the customer’s responsibility. Irricontrol is not responsible for equipment operation during peak hours due to incorrect configuration of holidays and/or weekdays.



8.2.8. Power Delay

The POWER DELAY option allows configuring the delay time before the pivot operation resumes after a power outage. The parameter can be set to OFF, where the operation restarts immediately after a power outage, or adjusted up to 59 minutes.



Figure 40 - Power Delay.



It is recommended that the OFF option for the POWER DELAY parameter be selected only in regions with a high-quality electricity supply and low incidence of power outages and voltage fluctuations.

8.2.9. Autoreverse

The AUTOREVERSE mechanism allows the automatic change of the pivot's movement direction. This option is commonly used in pivots installed in areas with limited rotation (less than 360°), and can be set to:

- A. OFF – The pivot's movement direction does not change automatically.



Figure 41 - Autoreverse - OFF Mode.



B. ON – In this mode, TIME and MODE must be set.



Figure 42 - Autoreverse - ON Mode.

- TIME – Time during which the pivot remains stopped at a specific position before starting movement in the opposite direction. This time can be set from 30 seconds up to 2 minutes. It is necessary to ensure that irrigation occurs uniformly within the defined operation boundary area.
- MODE – Defines the autoreverse activation mode, which can be set to:
 - SWITCH – The direction of movement changes when the pivot reaches and activates the limit switch.
 - ANGLE – The direction of movement changes when the pivot reaches the angle defined in parameter **(8.2.2. Sector)**.



The ANGLE option in the AUTOREVERSE MODE can only be accessed on equipment that has Irrimesh and GPS properly installed and connected.

8.2.10. GPS Coordinates

In this field, it is possible to enter the geographic coordinates of the pivot's central tower and the "zero degree" reference for angle measurement. This information enables the equipment to operate based on angle.

On the first page, the geographic coordinates of the pivot's central tower (CENTER LATITUDE/LONGITUDE) must be defined.

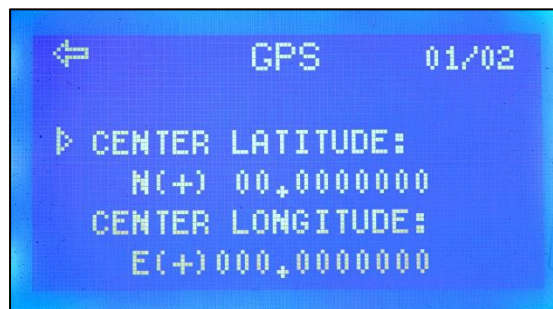

Figure 43 - Geographical coordinates of the pivot's central tower.

On the second page, the NORTH REFERENCE option defines the coordinate of the "zero degree" point, which can be:

- YES – The map's north position is used as the reference.
- NO – It is necessary to enter the geographic coordinates of the "zero degree" point (REFERENCE LATITUDE/LONGITUDE).

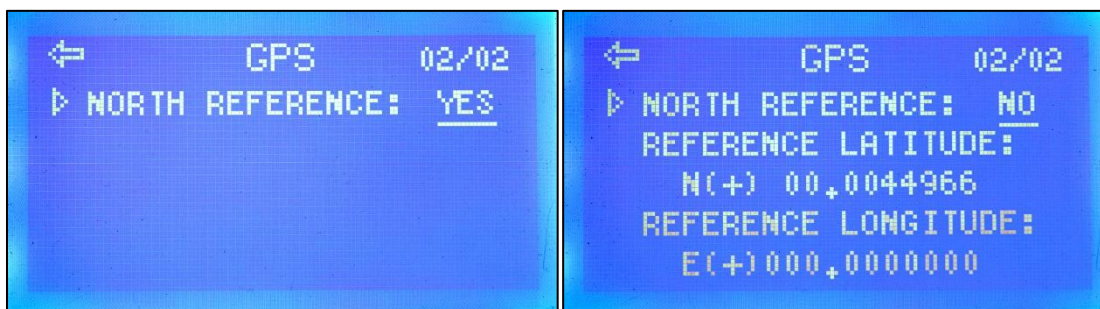

Figure 44 - Geographical coordinates of the reference point (NORTH REFERENCE: YES/NO).



It is recommended to use Google Earth or similar tools to obtain geographic coordinates.



8.2.11. Radio

The RADIO field is where the available radio transmitters in the irrigation system are enabled. It is necessary to select the device to be registered and enter the number corresponding to the XBee radio identifier (XBee ID). This process must be repeated for the GPS, CENTRAL, and PUMP (SPOTi) devices.

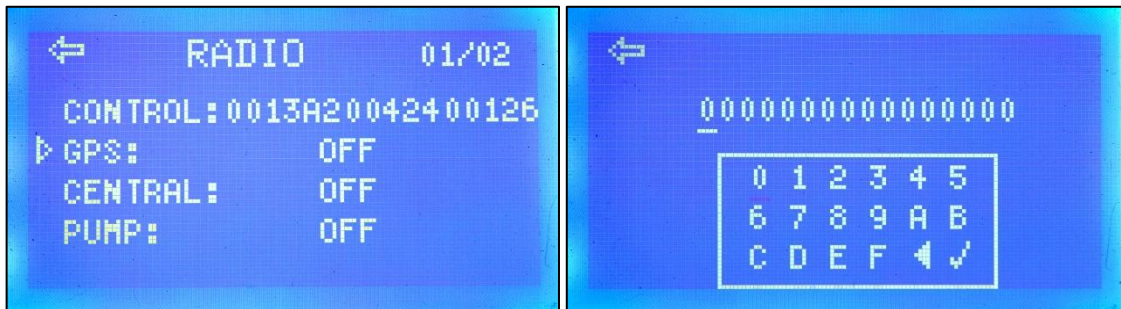

Figure 45 - Registration of radios numbers of the irrigation system devices.

To delete characters while typing the XBee radio number, select the highlighted item in Figure 46.



Figure 46 - Delete characters from the radio number (ID).

After entering the complete number, select the indicated character in Figure 47 to confirm.



Figure 47 - Confirm the entered radio number (ID).

The radio communicator ID can be found on the label attached to the XBee used in the Irricontrol electronic boards, as shown in Figure 48.



Figure 48 - XBee radio used in Irricontrol products.

After entering the radio IDs, it is possible to configure (send the information) and perform the signal test, as shown in Figure 49.



Figure 49 - Screen for initiating signal tests.

In this case, a confirmation message is displayed, informing that the pivot will be turned on without moving during the configuration and testing. Once confirmed, an animation appears showing that the device is searching for the GPS/PUMP signal, as shown in Figure 50.

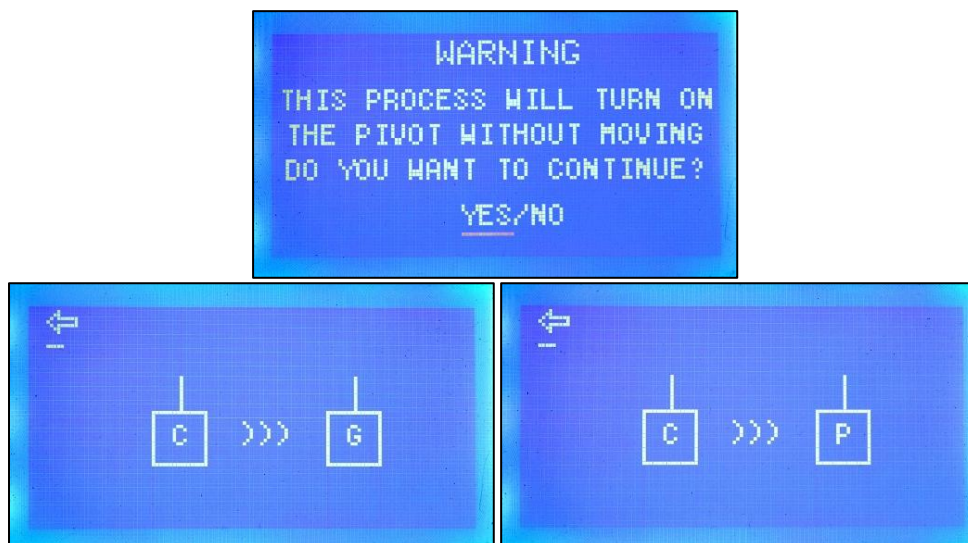

Figure 50 - Signal testing of the smart irrigation solution devices.

If the signal is below the minimum required to maintain communication, an animation with an "x" will be displayed, indicating a communication failure. If the value is within the required minimum range, the measured signal will be displayed on the screen, confirming the communication.

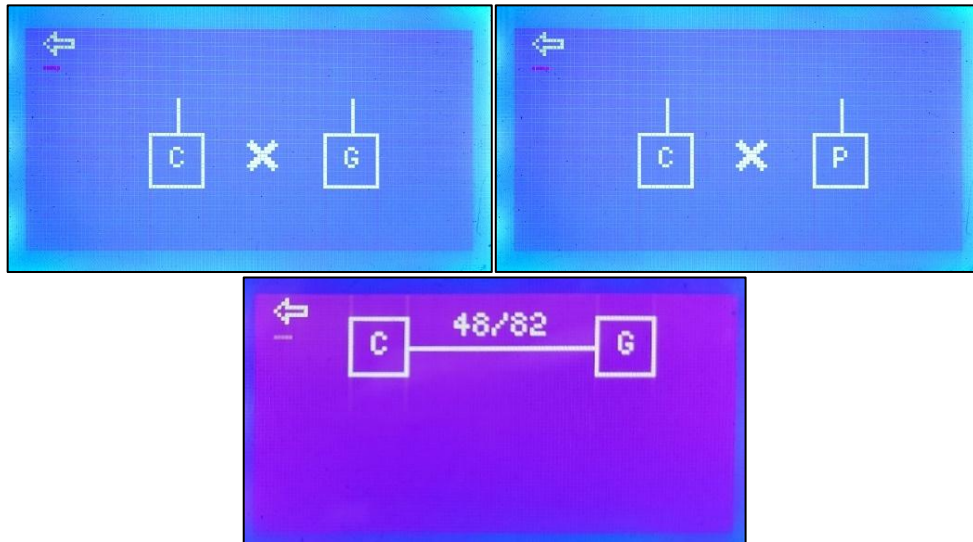

Figure 51 - Signal Test Results.

This allows the evaluation of the XBee radio communicator's signal quality, according to the following table:

POWER	QUALITY
Up to -70 dBm	Very good
Up to -80 dBm	Good
Up to -90 dBm	Moderate
-100 dBm	Weak

8.2.12. Injection Pump

Although the SmartConnect cabinet has a 480 VAC outlet that allows powering and using auxiliary pumps (such as those used in fertigation), the injection pump control function is incompatible with the SmartConnect cabinets G2. However, this functionality remains available since other products in the Irricontrol line, such as the Nexus cabinets, which use the same controller model, support this feature.

In compatible equipment, the parameter responsible for controlling the injection pumps via the cabinet (INJECTION PUMP field) must be configured according to the presence or absence of this type of pump.

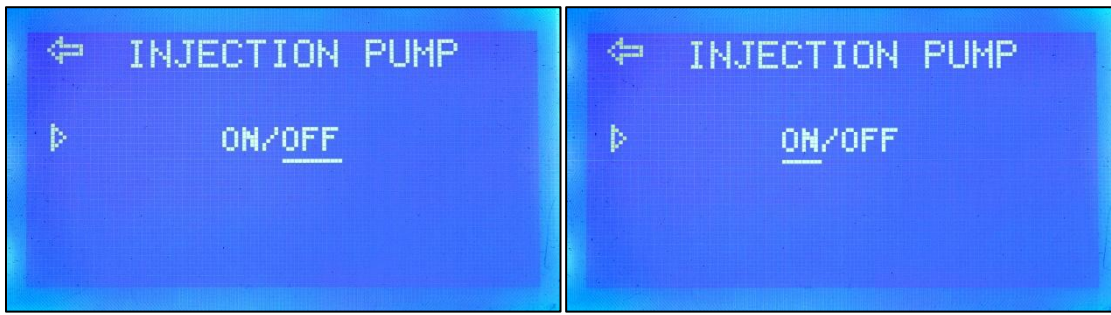

Figure 52 - Injection Pump - OFF and ON Modes.

- A. OFF – Applicable when there is no injector pump in the system or when it is present but should remain off.
- B. ON – Applicable when there is an injector pump in the system that needs to operate simultaneously with the main pump. In this mode, when the pivot is activated in WET mode, both the irrigation pump(s) and the parallel pump(s) start operating simultaneously.



Since the function is not compatible with the SmartConnect line, injection pump control via the cabinet is not possible, and the parameter must be kept in OFF mode.



The SmartConnect cabinet's 480 VAC outlet keeps the auxiliary pumps powered and available for use 100% of the time.



8.2.13. Voltage Limits

The VOLTAGE LIMITS option is used to set the acceptable voltage range for safe and proper operation. If the supply voltage is outside this range, the pivot will automatically shut down. This option can be set to OFF or ON.

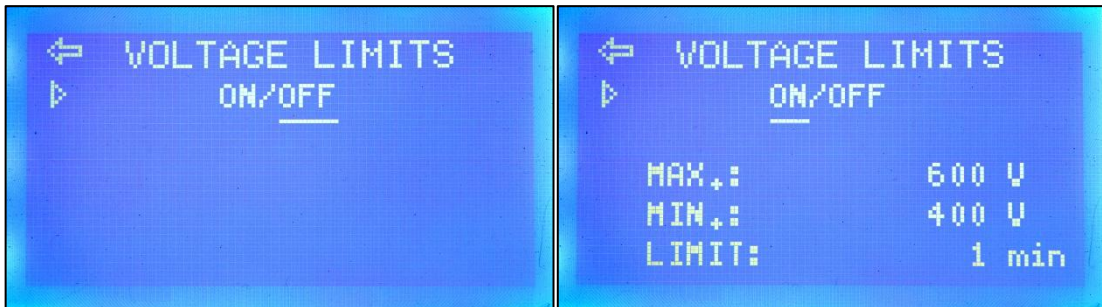

Figure 53 - Voltage Limits - OFF and ON Modes.

- A. OFF – Option disabled.
- B. ON – It is necessary to define MAX., MIN., and LIMIT:
- MAX. – Maximum supply voltage.
 - MIN. – Minimum supply voltage.
 - LIMIT – Maximum operation time allowed when the supply voltage is outside the defined range.



The values for this parameter should be set according to the client's preference and the characteristics of the electrical power supplied to the pivot.



The values entered are the responsibility of the client. It is not recommended that these exceed the equipment's operational limits.



8.2.14. Voltage Calibration

The VOLTAGE CALIBRATION option allows correcting possible discrepancies in the voltage reading displayed by the equipment. The value shown by the system appears in the VOLTAGE field, while the REFERENCE field should be filled with the actual voltage value measured at the transformer input using a multimeter.

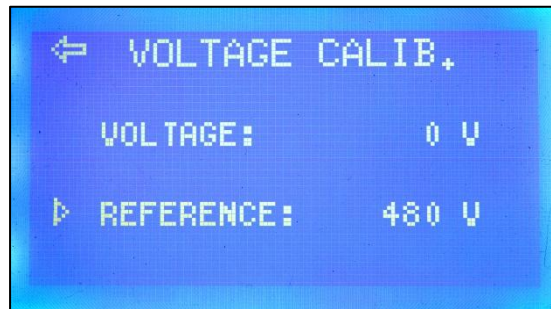

Figure 54 - Voltage Calibration.

8.2.15. Operation Time

On this screen, the operation time of the irrigation system equipment, the operation time in wet mode, and the total operation time of the equipment are displayed.

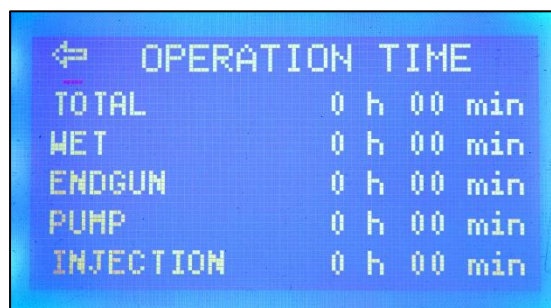

Figure 55 - Operation Time.



8.2.16. Rainmeter

On the first screen of the RAINMETER option, it is possible to select OFF or ON.

- C. OFF – Applicable when there is no rain gauge in the system or when the value measured by the rain gauge should not affect the pivot operation. In this case, the value will be recorded and available for consultation.



Figure 56 - Rainmeter - OFF Mode.

- D. ON – Applicable when there is a rain gauge installed in the system. In this case, it is necessary to define the STOP CONDITION, which can be either DECREMENT or VALUE:
- DECREASE – The value recorded by the rain gauge is subtracted from the set irrigation depth.
 - VALUE – When the rain gauge records the defined value, irrigation is automatically stopped.

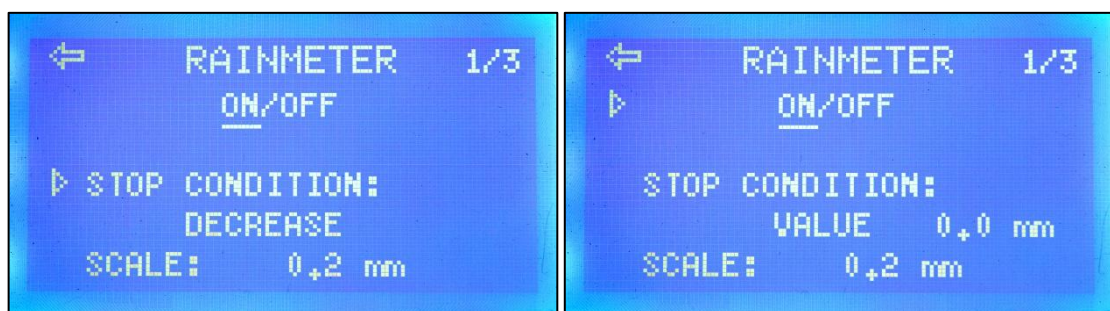

Figure 57 - Rainmeter - ON Mode.



The SCALE is set according to the specifications of the rain gauge used. Commonly, the rain gauges employed by Irricontrol operate on a scale of 0.2 millimeter.



On the second screen, the values recorded daily and monthly are displayed.

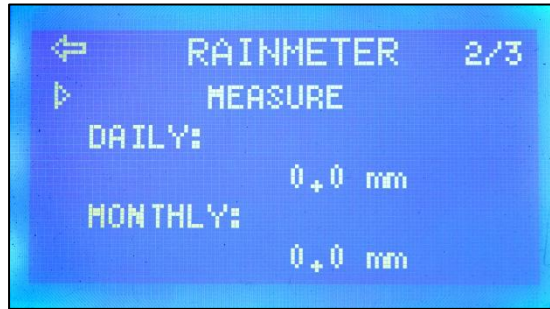

Figure 58 - Rainmeter - Daily/Monthly Records.

The third screen provides options for testing the rain gauge, if necessary, and for clearing all recorded rainfall data (both monthly and daily).



Figure 59 - Rainmeter - Test and Clear All Options.



8.2.17. Time Range

The TIME RANGE option allows defining specific time intervals and days of the week to record the operating time of the equipment that make up the irrigation system. This information can be relevant when the customer wants detailed data on the operating time of the equipment, separately.

It is possible to add up to ten time ranges. Each time a range is added, a new screen is automatically made available to enter the next range.

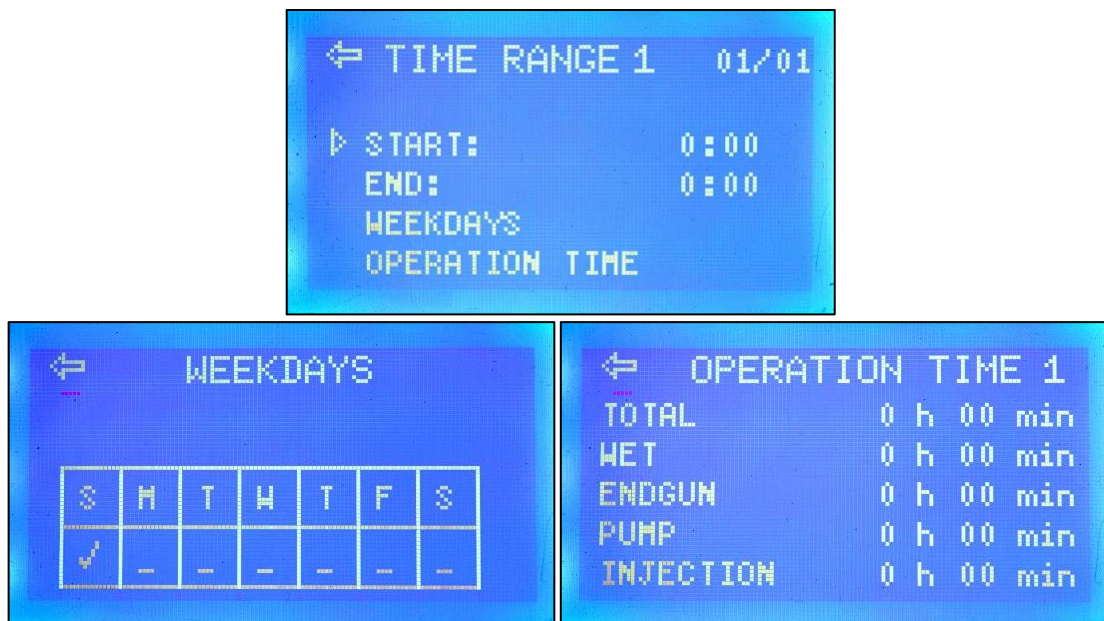

Figure 60 - Time Range.

8.2.18. Language

The SmartConnect G2 cabinet controller allows its menu to be displayed in up to five languages: English, Portuguese, German, Spanish, and Russian.

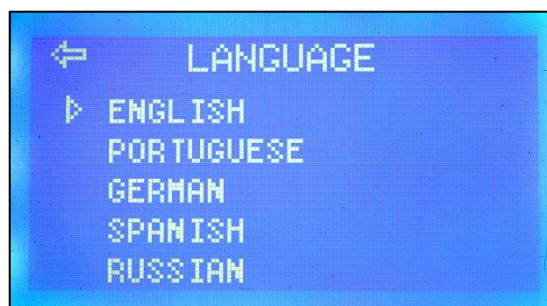

Figure 61 - Controller Languages.

8.2.19. Error Log

In the ERROR LOG option, it is possible to view the errors recorded during the operation of the pivot. The display shows the error code, the date, and the time of occurrence. If the user wishes to obtain more details about a specific fault, they simply need to access it. A second screen will open with the available information.

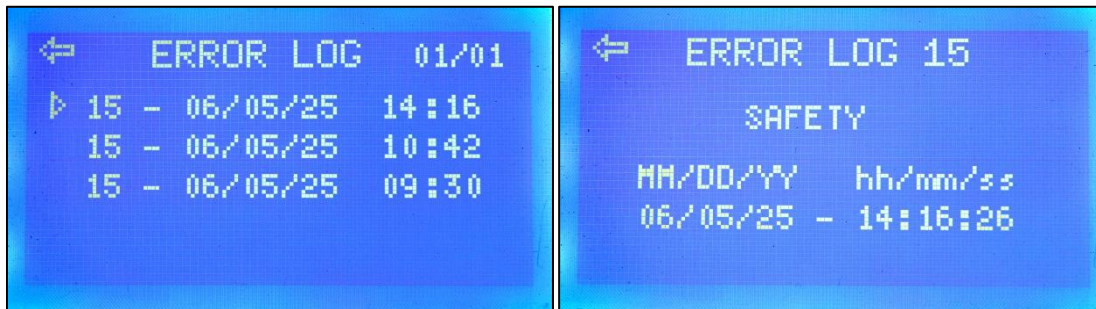

Figure 62 - Error Log.

The following table shows the error codes and descriptions of possible faults:

CODE	FAULT DESCRIPTION
15	Pivot stopped due to misalignment.
16	Pivot stopped due to pressure drop.
17	Pivot set in dangerous direction.
18	Power outage.
19	Voltage out of safe range.
20	Invalid parameter error.
21	Pivot stopped due to unknown error.
23	Error due to exceeded pump operation time.
32	Error when remotely starting the pump (SPOTi).



8.2.20. Pressure Fail Configuration

The PRESSURE FAIL option allows configuring the behavior of the irrigation system in case the system pressure exceeds the allowed maximum or minimum values. The settings available are:

- A. OFF – If a pressure failure occurs, the equipment will remain stopped until a new command is sent.



Figure 63 - Pressure Fail - OFF Mode.

- B. ON – If a pressure failure occurs, the pivot will attempt to resume operation after the pressure drop, according to the selected settings.

In this mode, it is necessary to define TIME TO RESTART, MAX. ATTEMPTS and TIME TO RESET:

- TIME TO RESTART – Time the pivot will remain stopped before resuming operation (from 0 to 30 minutes).
- MAX. ATTEMPTS – Maximum number of attempts to resume operation (from 0 to 5 attempts).
- TIME TO RESET – Minimum time between failures for an attempt to be counted (from 0 to 60 minutes).



Figure 64 - Pressure Fail - ON Mode.

8.2.21. Alignment

The ALIGNMENT option allows executing the pivot alignment procedure if its operation is interrupted due to a safety issue (misalignment). For this, the safety components are temporarily disabled, allowing the pivot to move in the correct direction.

When this function is activated, the user must select the alignment direction (FORWARD/REVERSE). Once selected, all drive towers except the last one will be activated to assist in the process. The equipment will only stop when the STOP button on the controller is pressed.

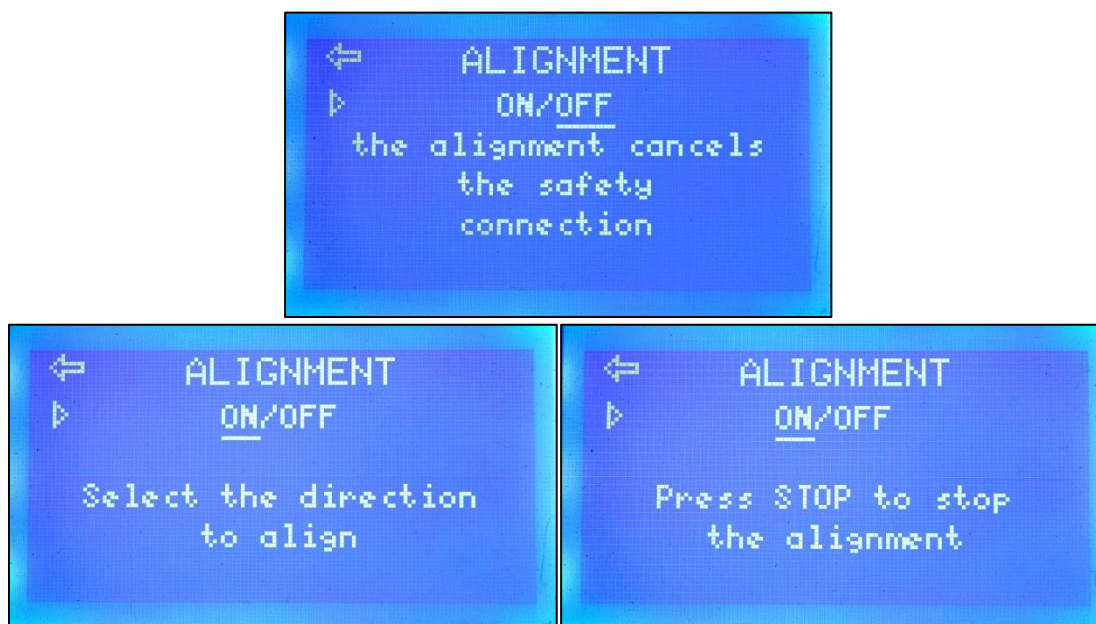

Figure 65 - Alignment.



This function is recommended for use only in environments with a clear view of the entire pivot length, minimizing accident risks and ensuring safe operation.

8.2.22. About

On the ABOUT screen, it is possible to view all relevant information about the equipment, such as hardware version, firmware version, radio communication protocol, and the radio controller identifier (ID).



Figure 66 - Product Information.

9. Emergency Systems

Given that risk situations may arise suddenly during pivot operation, it is essential that the equipment can be immediately shut down when necessary.

In such cases, the Emergency Button must be fully pressed. This action de-energizes the cabinet and interrupts all active commands, whether in analog mode, digital mode, or through the platform.



Figure 67 - Emergency Button Location.

To resume operation, the button must be returned to the “NEUTRAL” position by turning it clockwise, and the desired command must be sent again.



Figure 68 - Return of the Emergency Button to the “NEUTRAL” position.



10. Testing Procedure

All products manufactured and sold by Irricontrol Controle Inteligente de Irrigação S/A undergo rigorous quality tests to ensure full functionality. However, due to the characteristics of field installation and the need for integration with external components, the SmartConnect G2 must be tested again after installation and configuration. In addition to testing the equipment, this procedure aims to verify the entire irrigation system and ensure that it is in proper condition for operation.

During this process, the ANALOG and DIGITAL modes, as well as the EMERGENCY SYSTEM, must be tested.



The test procedure must be carried out during the equipment's first operation (after installation), whenever the pivot remains out of service for extended periods (such as between crop seasons), and after maintenance activities.



The testing procedure must only be carried out after the complete installation of the irrigation system, cabinet configuration, and confirmation that there are no obstacles in the pivot's movement area.



If any abnormality is detected during testing, the irrigation system installation must be reviewed, and section **12. Failures and Possible Causes** should be consulted.

10.1. ANALOG Mode Testing

To ensure the ANALOG system of the SmartConnect G2 cabinet is functioning correctly, the following commands must be sent using the analog buttons:



Instructions for accessing ANALOG mode, as well as the correct way to execute commands, are described in section **11.1. Operation - ANALOG Mode**.

- A. Send the FORWARD command in DRY mode and wait until all drive towers move (forward).
- B. Turn the "REVERSE/FORWARD" selector switch to the neutral position, corresponding to the STOP command, and wait for the pivot to complete its movement.
- C. Send the REVERSE command in DRY mode and wait until all drive towers move (reverse).
- D. Send the STOP command and wait until the pivot completes its movement.



- E. Send the FORWARD command in WET mode and wait until the pivot is pressurized and begins moving with irrigation (forward).
- F. Send the STOP command and wait until the pivot completes its movement.
- G. Send the REVERSE command in WET mode and wait until the pivot is pressurized and begins moving with irrigation (reverse).
- H. Send the STOP command and wait until the pivot completes its movement.

10.2. DIGITAL Mode Testing

To ensure the DIGITAL system of the SmartConnect G2 cabinet is functioning correctly, the following commands must be sent using the digital controller:



Instructions for accessing DIGITAL mode, as well as the correct way to execute commands, are described in section **11.2. Operation - DIGITAL Mode**.

- A. Send the FORWARD command in DRY mode and wait until all drive towers move sufficiently (forward), ensuring they are operating correctly.
- B. Send the STOP command and wait until the pivot completes its movement.
- C. Send the REVERSE command in DRY mode and wait until all drive towers move sufficiently (in reverse), ensuring they are operating correctly.
- D. Send the STOP command and wait until the pivot completes its movement.
- E. Send the FORWARD command in WET mode and wait until the pivot is pressurized and begins moving with irrigation (forward).
- F. Send the STOP command and wait until the pivot completes its movement.
- G. Send the REVERSE command in WET mode and wait until the pivot is pressurized and begins moving with irrigation (in reverse).
- H. Send the STOP command and wait until the pivot completes its movement.
- I. Send a movement command (FORWARD or REVERSE) in DRY or WET mode and disconnect the SAFETY OUTPUT cable (White Wire, Wire N°20, Terminal 07). The operation must stop, and the message “SAFETY” should appear on the controller and the Irricontrol platform.





This step ensures the proper functioning of the safety system that prevents the pivot from continuing operation in case of critical misalignment.

- J. Send a movement command (FORWARD or REVERSE) in WET mode. As soon as the pivot is pressurized and starts moving, disconnect the PRESSURE SWITCH cable (Terminal 11). The operation must stop, and the message “PRESSURE FAILURE” should appear on the digital controller and the Irricontrol platform.



This step ensures the proper functioning of the safety system that prevents the pivot from continuing operation in case of pressure failure.

10.3. EMERGENCY SYSTEM Testing

To ensure the Emergency System is functioning correctly, it is necessary to test the operation of the EMERGENCY BUTTON and the MAIN SWITCH (or SAFETY SWITCH).

- A. EMERGENCY BUTTON – Send any movement command (operation mode and direction as per customer preference). As soon as the pivot starts moving, press the Emergency Button and verify that the equipment is immediately stopped and de-energized.



Figure 69 - Emergency Button Test.



B. MAIN SWITCH – Send any movement command (operation mode and direction as per customer preference). As soon as the pivot starts moving, turn the Main Switch counterclockwise to the “OFF” position and verify that the equipment is immediately stopped and de-energized.

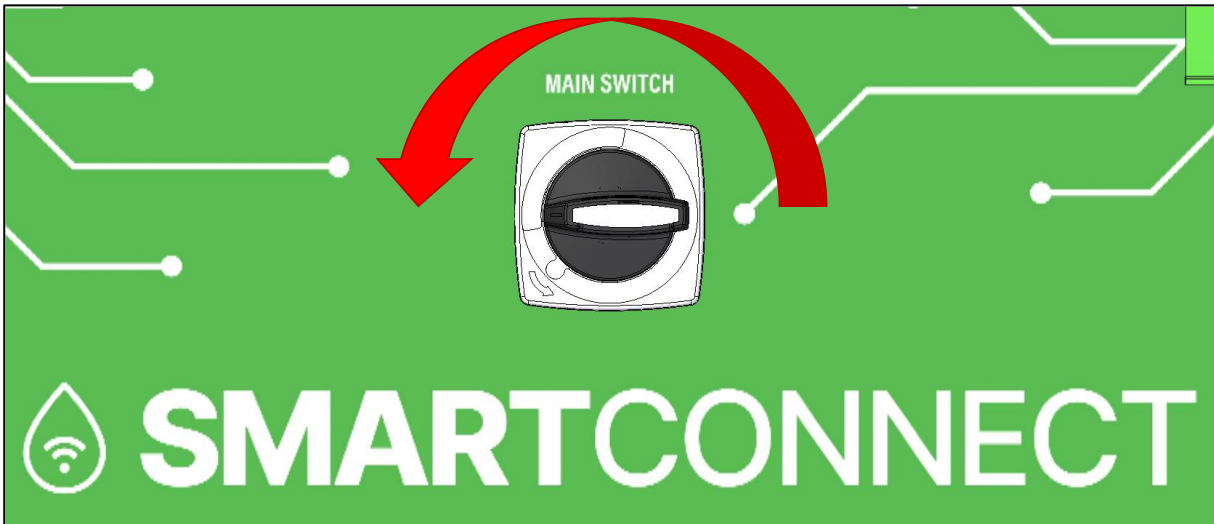

Figure 70 - Main Switch Test.



Instructions for using the emergency system can be found in section **9. Emergency Systems**.



11. Equipment Operation

The operation of the SmartConnect G2 can be configured directly on the cabinet, via the controller, or through the Irricontrol Platform.

On the controller, it is possible to set the operation in ANALOG or DIGITAL mode. In DIGITAL mode, operations can be configured as simple, by segment, or by schedule, while in ANALOG mode, only simple operations can be configured.



During operation, if the equipment exhibits any abnormality or failure, refer to section **12. Failures and Possible Causes**. If the issues persist, contact Irricontrol Technical Support.

11.1. Operation - ANALOG Mode

The operation of the SmartConnect G2 cabinet in ANALOG mode is defined using the selector switches and the “START” button located on the inner door of the equipment, highlighted in Figure 71.

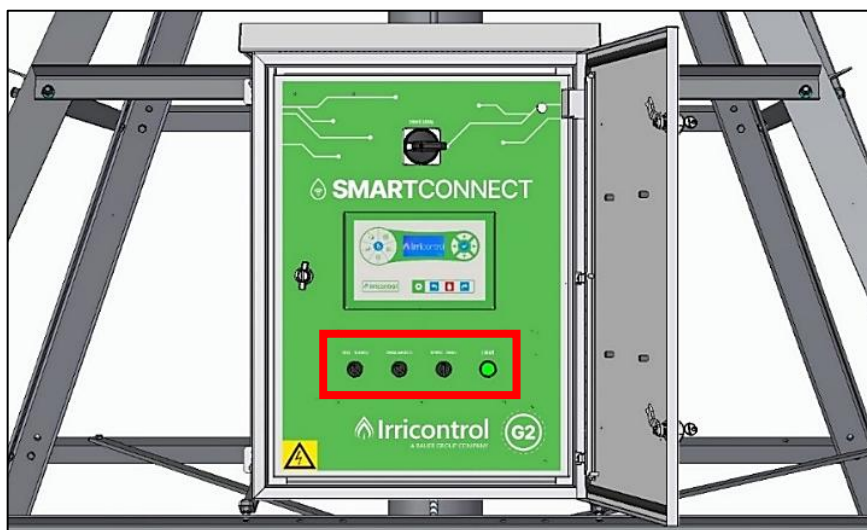

Figure 71 - ANALOG Controls of the Cabinet.

To operate the equipment in this mode, select the “ANALOG” option on the “DIGITAL/ANALOG” selector switch by turning it clockwise, as shown in Figure 72.



Figure 72 - ANALOG Mode Selection.



Once this is done, the controller display will turn off, as shown in Figure 73.



Figure 73 - ANALOG Mode Activation Indicator: display off.

11.1.1.1. Operation in Dry Mode - ANALOG

To operate the equipment in ANALOG and DRY mode:

- A. Turn the “DRY/WET” selector switch 45° counterclockwise.

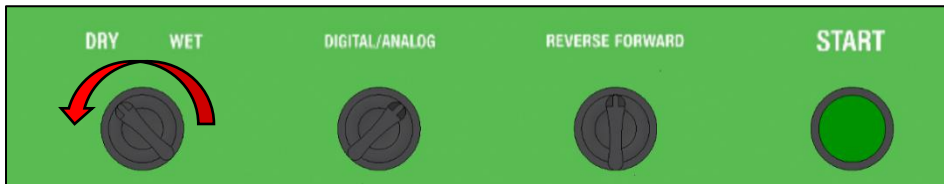

Figure 74 - DRY Mode Operation - ANALOG.

- B. Turn the “REVERSE/FORWARD” selector switch 45° clockwise for FORWARD, and counterclockwise for REVERSE, according to the operation needs.

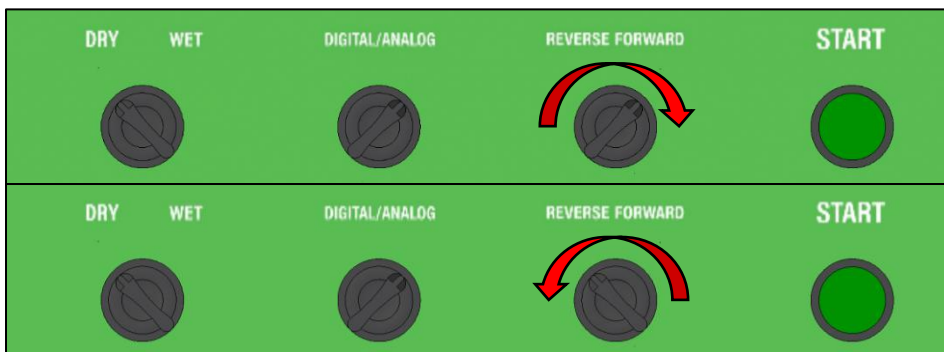

Figure 75 - FORWARD/REVERSE Commands in DRY Mode - ANALOG.

C. Press the “START” button to start pivot movement.

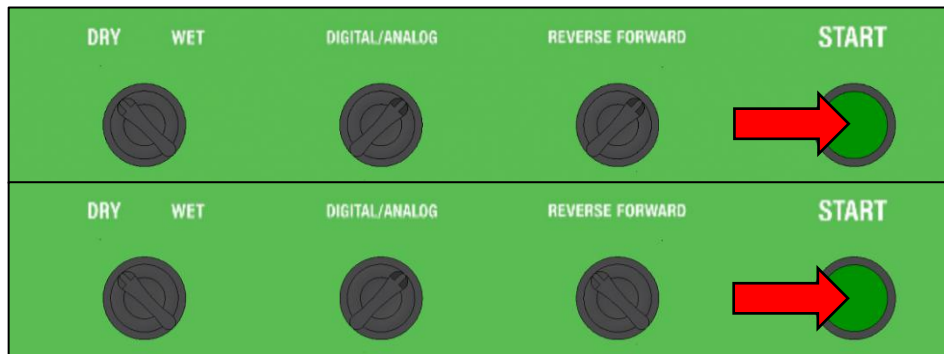

Figure 76 - START Command in DRY Mode.

D. If it is necessary to stop the pivot movement, turn the “REVERSE/FORWARD” selector switch to the neutral position.

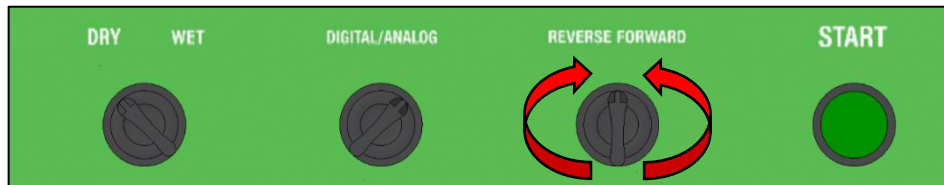



Figure 77 - Pivot Movement Stop in DRY Mode - ANALOG.

 If the previous movement was FORWARD, turn the “REVERSE/FORWARD” selector switch 45° counterclockwise to stop the operation.

 If the previous movement was REVERSE, turn the “REVERSE/FORWARD” selector switch 45° clockwise to stop the operation.

11.1.2. Operation in WET Mode - ANALOG

To operate the equipment in ANALOG and wet mode:

A. Turn the “DRY/WET” selector switch 45° clockwise.



Figure 78 - WET Mode Operation - ANALOG.

- B. Turn the “REVERSE/FORWARD” selector switch 45° clockwise for FORWARD, and counterclockwise for REVERSE, according to the operation needs.

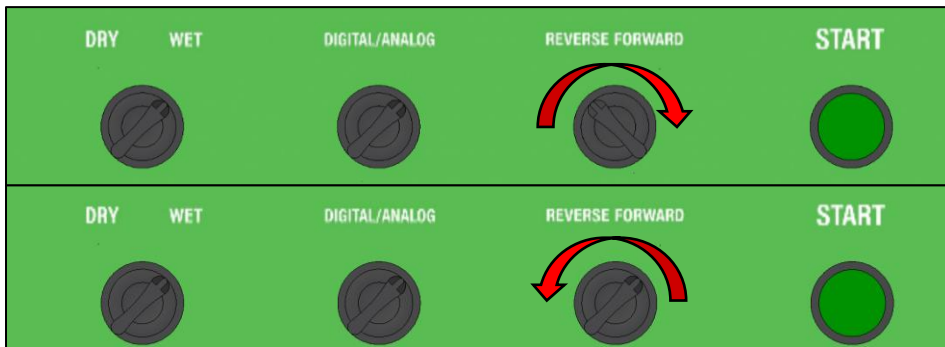

Figure 79 - FORWARD/REVERSE Commands in WET Mode - ANALOG.

- C. Press the “START” button to start pivot movement.



Figure 80 - START Command in WET Mode.

- D. If it is necessary to stop the pivot movement, turn the “REVERSE/FORWARD” selector switch to the neutral position.



Figure 81 - Pivot Movement Stop in WET Mode - ANALOG.



If the previous movement was FORWARD, turn the “REVERSE/FORWARD” selector switch 45° counterclockwise to stop the operation.



If the previous movement was REVERSE, turn the “REVERSE/FORWARD” selector switch 45° clockwise to stop the operation.

11.2. Operation - DIGITAL Mode

To operate the SmartConnect G2 cabinet in DIGITAL mode, make sure the “DIGITAL/ANALOG” selector switch is in the “DIGITAL” position. If not, turn it 45° counterclockwise, as shown in **Erro! Fonte de referência não encontrada..**

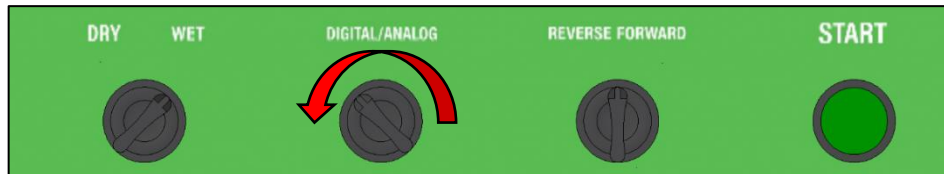

Figure 82 - DIGITAL Mode Selection.

Once this is done, the controller display will be powered on and initialized (this process may take approximately 25 seconds).

11.2.1. Operation in Simple Irrigation Mode - DIGITAL

In SIMPLE irrigation mode, it is possible to define the operation mode, percentage timer/precipitation, operation start, and pivot stop mode.

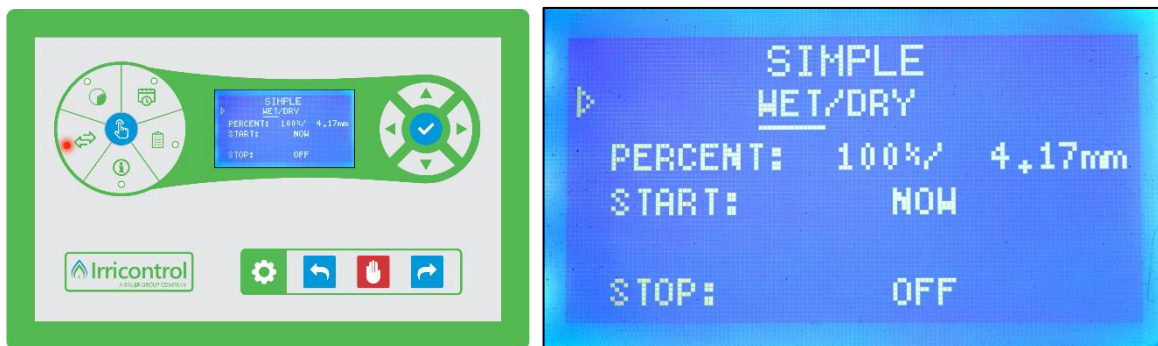

Figure 83 - Operation in Simple Irrigation Mode - DIGITAL.

A. OPERATION MODE – The operation can occur in WET or DRY mode:

- WET – In this mode, the main pump is activated as soon as the pivot starts moving, after the FORWARD/REVERSE command is sent.
- DRY – In this mode, the main pump remains off even while the pivot is in motion.

B. PERCENTAGE TIMER – Sets the pivot’s operating speed. The closer to 100%, the faster the pivot will move, meaning it will take less time to complete a full 360° rotation. It should be set according to the customer’s needs or preferences.



The pivot's operating speed is limited by the gear motors.



The percentage timer parameter inversely affects the precipitation parameter.

C. PRECIPITATION – Defines the depth of water to be applied during pivot operation.



The precipitation parameter inversely affects the percentage timer parameter.

D. START – Defines the start of the operation, which can be:

- NOW – The operation will start immediately after the FORWARD or REVERSE command is sent.
- DATE – Allows scheduling the date and time for the pivot to start moving.

E. STOP MODE – Indicates when the pivot operation should end. The available options are:

- OFF – The pivot stops immediately after the STOP command is sent.
- ANGLE – The pivot stops automatically upon reaching a predefined angle, without requiring the STOP command.
- ROUNDS – The pivot stops after completing the predefined number of operation cycles, without requiring the STOP command. Each operation cycle corresponds to one full (360°) rotation of the pivot.
- END SECTOR – The pivot stops automatically upon reaching the end of the sector, as defined in the configuration (section **8.2.2. Sector**), without requiring the STOP command.



11.2.2. Operation in Segment Irrigation Mode - DIGITAL

In SEGMENT irrigation mode, it is possible to set different operating configurations for each created segment, depending on the customer's needs and/or preferences.

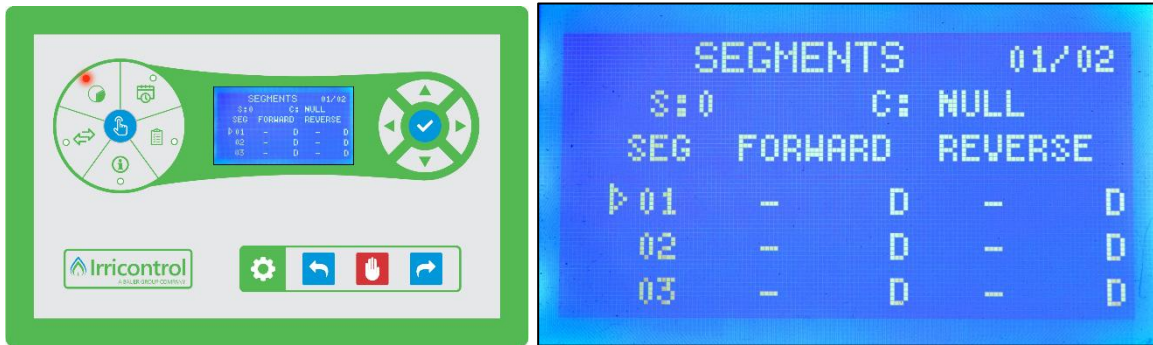

Figure 84 - Operation in Segment Irrigation Mode - DIGITAL.

In this option, the following fields are available:

- A. NUMBER OF SEGMENTS – Value set in the configuration (**8.2.3. Segments**), according to the customer's needs and/or preferences. Each created segment can have its own parameters individually adjusted.
- B. OPERATION MODE – The operation can occur in WET or DRY mode. To select the mode, it is necessary to access the desired segment.
 - WET – In this mode, the main pump is activated as soon as the pivot starts moving, after the FORWARD/REVERSE command is sent.
 - DRY – In this mode, the main pump remains off even while the pivot is in motion.
- C. PERCENTAGE TIMER – Sets the pivot's operating speed. The closer to 100%, the faster the pivot will move, meaning it will take less time to complete a full 360° rotation. It should be set according to the customer's needs or preferences.



The pivot's operating speed is limited by the gear motors.



The percentage timer parameter inversely affects the precipitation parameter.

D. PRECIPITATION – Defines the depth of water to be applied during pivot operation.



The precipitation parameter inversely affects the percentage timer parameter.

E. START - Defines the start of the operation, which can be:

- NOW – The operation will start immediately after the FORWARD or REVERSE command is sent.
- DATE – Allows scheduling the date and time for the pivot to start moving.

F. STOP MODE – Indicates when the pivot operation should end. The available options are:

- OFF – The pivot stops immediately after the STOP command is sent.
- ANGLE – The pivot stops automatically upon reaching a predefined angle, without requiring the STOP command.
- DATE – The stop occurs only at the predefined date and time, without requiring the STOP command to be sent.
- ROUNDS – The pivot stops after completing the predefined number of operation cycles, without requiring the STOP command. Each operation cycle corresponds to one full (360°) rotation of the pivot.
- END SECTOR – The pivot stops automatically upon reaching the end of the sector, as defined in the configuration (section **8.2.2. Sector**), without requiring the STOP command.



11.2.3. Operation in Schedule Irrigation Mode - DIGITAL

The SCHEDULE irrigation mode allows the pivot operation to be scheduled by setting the start date and time, operating mode, movement direction (FORWARD/REVERSE), percentage timer/precipitation, and stop mode.



Figure 85 - Operation in Schedule Irrigation Mode - DIGITAL.

- A. OPERATION MODE – The operation can occur in WET, DRY or NONE mode. To select the mode, it is necessary to access the desired segment.
- WET – In this mode, the main pump is activated as soon as the pivot starts moving, after the FORWARD/REVERSE command is sent.
 - DRY – In this mode, the main pump remains off even while the pivot is in motion.
 - NONE – Indicates that no irrigation is scheduled for the segment.
- B. PERCENTAGE TIMER – Sets the pivot’s operating speed. The closer to 100%, the faster the pivot will move, meaning it will take less time to complete a full 360° rotation. It should be set according to the customer’s needs or preferences.

 The pivot’s operating speed is limited by the gear motors.

 The percentage timer parameter inversely affects the precipitation parameter.

C. PRECIPITATION – Defines the depth of water to be applied during pivot operation.



The precipitation parameter inversely affects the percentage timer parameter.

D. START – Allows scheduling the date and time for the pivot to start moving.

E. STOP MODE – Indicates when the pivot operation should end. The available options are:

- OFF – The pivot stops immediately after the STOP command is sent.
- ANGLE – The pivot stops automatically upon reaching a predefined angle, without requiring the STOP command.
- DATE – The stop occurs only at the predefined date and time, without requiring the STOP command to be sent.
- ROUNDS – The pivot stops after completing the predefined number of operation cycles, without requiring the STOP command. Each operation cycle corresponds to one full (360°) rotation of the pivot.
- END SECTOR – The pivot stops automatically upon reaching the end of the sector, as defined in the configuration (section **8.2.2. Sector**), without requiring the STOP command.



12. Failures and Possible Causes

Due to the technical characteristics of pivot operation and the environment in which it is installed, the equipment is subject to several factors that may cause it to enter failure mode. These failures may result from local conditions, operational errors, or, in rare cases, product-related issues.

Under such conditions, the system will immediately shut down, and a message detailing the occurrence will be displayed on the controller screen and on the Irricontrol platform. The following are some failures, their possible causes, and recommended solutions.



In cases where it is not possible to identify the causes of the failures and/or the error persists, contact Irricontrol Technical Support.



After identifying and resolving the failure, it will be necessary to send a new movement command (FORWARD/REVERSE) for the equipment to resume normal operation.

12.1. Digital controller constantly initializing

POSSIBLE CAUSES	SOLUTION
Incompatible power supply output voltage	- Adjust the power supply output voltage to 13 VDC.
Defective power supply	- Replace the power supply (contact Irricontrol Technical Support for guidance on the model to be used).
Incorrect electrical connection	- Check all electrical connections.
Controller issues	- Contact Technical Support.



12.2. Digital controller does not power on

POSSIBLE CAUSES	SOLUTION
Selector switch "DIGITAL/ANALOG" in ANALOG position	- Turn the "DIGITAL/ANALOG" selector switch to the DIGITAL position.
Cabinet power supply	- Ensure the cabinet is energized as specified.
Safety System ACTIVATED	- Turn the Emergency Button to the "NEUTRAL" position. - Turn the Main Switch to the "ON" position.
Burned power supply	- Replace the power supply (contact Irricontrol Technical Support for guidance on the model to be used).
Incorrect connection of the 13 VDC power supply	- Check the power supply connection.
Tripped or blown circuit breakers or fuses	- Reset or replace the components.
Incorrect electrical connection	- Check cabinet's electrical connections.
Controller issues	- Contact Technical Support.

12.3. Time Mismatch Error

The controller's date and/or time differs from the platform's date and/or time.

POSSIBLE CAUSES	SOLUTION
Incorrect time and/or date configuration	- Reconfigure the date and time as instructed in section 8.2.5. Clock .
Discharged controller battery	- Replace the battery as instructed in section 13.5.1 Replacement of the CR2032 3V battery.
Controller issues	- Contact Technical Support.

12.4. Pivot stopped due to misalignment - CODE 15

If the angle between the pivot spans exceeds the safe operating limits, the equipment will stop and the message "SAFETY" will be displayed.

POSSIBLE CAUSES	SOLUTION
Stuck pivot	- Free the pivot using manual mode.
Obstacles on tire path	- Remove obstacles.
Low tire pressure	- Check for tires leaks. - Properly calibrate the tires.
Tower control boxes failure	- Check the connections and the integrity of the tower control boxes.
Gearmotors failure	- Check the condition of the gearmotors. - Perform necessary maintenance. - Replace if necessary.



12.4.1. Realignment procedure

To resume equipment operation after misalignment, press the FORWARD or REVERSE button (in DIGITAL mode), depending on the direction of the misalignment. While the button is pressed, the safety system will be temporarily overridden, allowing the pivot to move. It is recommended that the movement be made in the direction opposite to the misalignment.



The procedure must be carried out with CAUTION and ATTENTION! It is necessary to ensure that the movement can be performed without putting the equipment or personnel in the operation area at risk.



The realignment procedure can also be performed through the Alignment parameter, as described in section 8.2.21. **Alignment**.

12.5. Pivot stopped due to pressure drop - CODE 16

The system pressure exceeds the configured limits.

POSSIBLE CAUSES	SOLUTION
Incorrect pressure configuration	- Configure the pressure-related parameters.
Pumping system failure	- Inspect the pumping system as specified by the manufacturer.
Water supply interruption	- Restore the water supply.
Critical leaks	- Check all system piping and hoses. - Repair leaks and/or replace damaged components.
Pressure switch out of adjustment or failure	- Adjust or replace the pressure switch according to the manufacturer's instructions.
Faulty pressure sensor	- Contact Technical Support.

12.6. Pivot set in dangerous Direction - CODE 17

The controller simultaneously receives FORWARD and REVERSE movement commands.

POSSIBLE CAUSES	SOLUTION
Simultaneous commands sent	- Send one command at a time. - Wait approximately 5 seconds between commands.
Incorrect electrical connection	- Check all electrical connections.
Controller issues	- Contact Technical Support.



12.7. Pivot stopped due to power failure - CODE 18

The cabinet power supply interrupted.

POSSIBLE CAUSES	SOLUTION
Burnt cabinet components	<ul style="list-style-type: none">- Inspect cabinet components.- Replace components if necessary.
External factors (interrupted power supply)	<ul style="list-style-type: none">- Replace components if necessary.- Contact the power supplier and distributor.

12.8. Pivot stopped due to voltage out of safe range - CODE 19

It occurs when there are fluctuations in the power supplied to the cabinet.

POSSIBLE CAUSES	SOLUTION
Incorrect Voltage Limit parameter configuration	<ul style="list-style-type: none">- Adjust the Voltage Limit parameter as specified in section 8.2.13. Voltage Limits.
Excessive equipment connected simultaneously	<ul style="list-style-type: none">- Follow the recommendations of the system's electrical project.
External factors (voltage variation)	<ul style="list-style-type: none">- Check the farm's electrical network.- Adapt the system to meet the demand.- Contact the power supplier and distributor.

12.9. Pivot stopped due to invalid parameter error - CODE 20

It occurs when there is a conflict in the information related to the selected irrigation mode.

POSSIBLE CAUSES	SOLUTION
Simultaneous commands sent	<ul style="list-style-type: none">- Send one command at a time.- Wait approximately 5 seconds between commands.
Incorrect electrical connection	<ul style="list-style-type: none">- Check all electrical connections.



12.10. Pivot stopped due to unknown error - CODE 21

Pre-failure condition or failure in the Irrifast control box (if installed in the system).

POSSIBLE CAUSES	SOLUTION
Pre-failure condition (e.g., manual forced misalignment, air entry or temporary obstruction in the pumping system, etc.)	- Send a new command to the equipment (via controller or platform).
Damaged microswitch	- Replace the damaged microswitch (except for Irrifast control boxes).
Misadjusted microswitch	- Adjust the microswitch (except for Irrifast control boxes).
HMI parameter set to ON	- Set the parameter to OFF.
Incorrect electrical connection	- Check all electrical connections.
Irrifast failure	- Refer to the FAILURES section in the Irrifast manual (if the pivot is equipped with this control box model).

12.11. Pivot stopped due to pump time exceeded - CODE 23

The pump operating time exceeded the set limit.

POSSIBLE CAUSES	SOLUTION
Incorrect pump time settings	- Configure the parameter correctly.
Pressure switch out of adjustment or failure	- Adjust or replace the pressure switch according to the manufacturer's instructions.
Pumping system issues	- Inspect the pumping system.
Incorrect electrical connection	- Check all electrical connections.

12.12. Error when connecting the remote pump - CODE 32

Failure in SPOTi activation.

POSSIBLE CAUSES	SOLUTION
SPOTi operational issues	- Check the operation of the SPOTi. - Check the operation of the pump drive system (soft-start, direct-on-line, variable frequency drive, etc.).

13. Additional Information and Precautions

This section contains essential additional information and precautions for the use and maintenance of your equipment. These guidelines are crucial to ensure not only optimal performance but also durability and safety. Attention to these complementary details contributes to a better user experience and maximizes the benefits of your investment.

13.1. Product Storage

To preserve the integrity of the equipment until installation, it is essential that storage and handling are carried out properly. The boxes should be kept in a dry, well-ventilated, and preferably covered area, adhering to a maximum stacking limit of four boxes. To avoid any damage to the equipment, all handling must be done with care.

13.2. Product Serial Number

The equipment’s serial number is essential for product control and traceability. It enables the individual identification of each unit, facilitating technical support, maintenance history tracking, and warranty procedures when necessary.

This number can be found on labels located on the product’s storage box and/or on the cabinet and the purchase invoice, as shown in Figure 86.

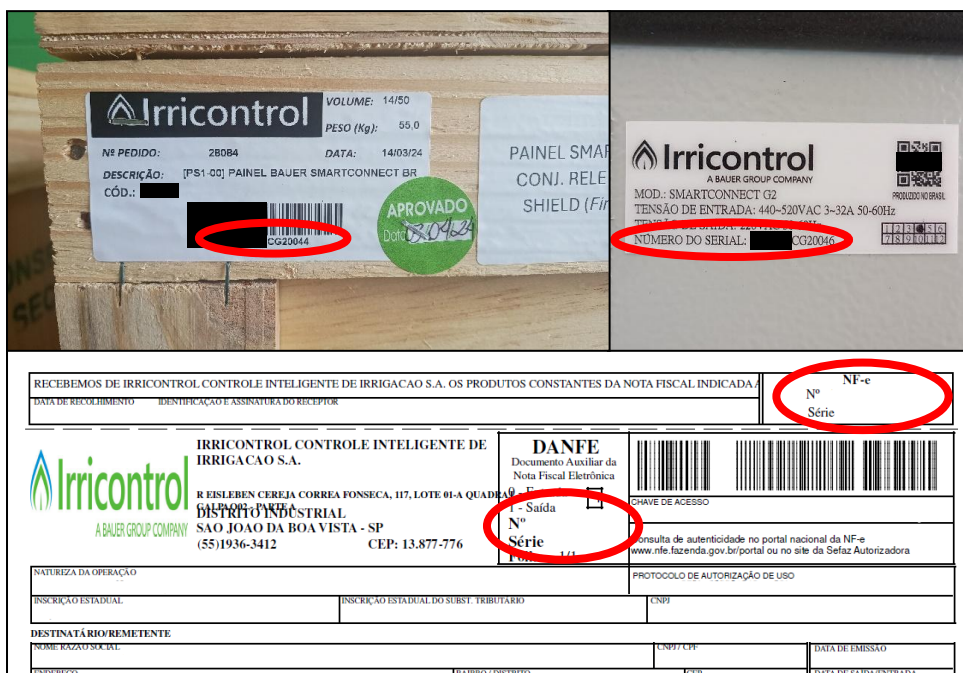

Figure 86 - Product Serial Number.



13.3. Disposal of the Product and/or Components

At the end of the product's life cycle, or in the event of component replacement, proper environmentally responsible disposal must be ensured in accordance with current legislation (e.g., National Solid Waste Policy – Law No. 12,305/2010).

- **Electronic items (boards, cables, modules, power supplies, connectors):** Must be taken to authorized collection points or companies specialized in electronic waste recycling to prevent soil and water contamination by heavy metals.
- **Batteries and accumulators:** Should never be disposed of in regular trash. Take them to designated battery collection points in accordance with CONAMA Resolution No. 401/2008.
- **Plastics and polymer materials (cabinets, supports, connectors):** Should be separated and sent for recycling according to material classification.
- **Metals (supports, screws, fasteners):** Can be directed to scrap metal recycling.
- **Packaging:** Should be disposed of in selective collection, whenever available, according to the material type (cardboard, plastic, etc.).



Improper disposal of electronic components can cause significant environmental impacts and is subject to legal penalties.



13.4. Electrical Power Quality

Ensuring the quality of the voltage supplied to the system is crucial to guarantee its performance and product longevity. Significant voltage fluctuations or inadequate power supply can negatively impact the equipment's functionality, leading to premature wear or operational failures. Making sure the equipment receives a stable power supply within the specified limits is essential to avoid issues caused by irregularities in the power supply, directly contributing to equipment preservation, extended lifespan, and system efficiency.

13.5. Periodic Maintenance

Performing periodic maintenance is essential to maintain the product's good performance and ensure its durability and safety. This section provides guidance on when to perform maintenance, which procedures to follow, and how to ensure all components are in perfect working condition. Adopting this maintenance routine contributes to system longevity, prevents unexpected failures, and guarantees operational continuity.

In addition to the points listed below, when the system remains idle for extended periods (e.g., between crop seasons), it is important to carry out a thorough inspection to identify potential looseness, damaged parts, or other issues that could compromise the integrity of the irrigation system.



13.5.1. Replacement of the CR2032 3V battery

The CR2032 3V battery is mounted on the Digital Controller board. If replacement is required, follow these steps:

- A. Disconnect the terminals of the Digital Controller.
- B. Unscrew the mouting clamps of the Digital Controller.
- C. Access the interior of the Digital Controller.
- D. Replace the CR2032 3V battery with a new one.
- E. Close the Digital Controller.
- F. Screw the mounting clamps of the Digital Controller.
- G. Reconnect the terminals of the Digital Controller.

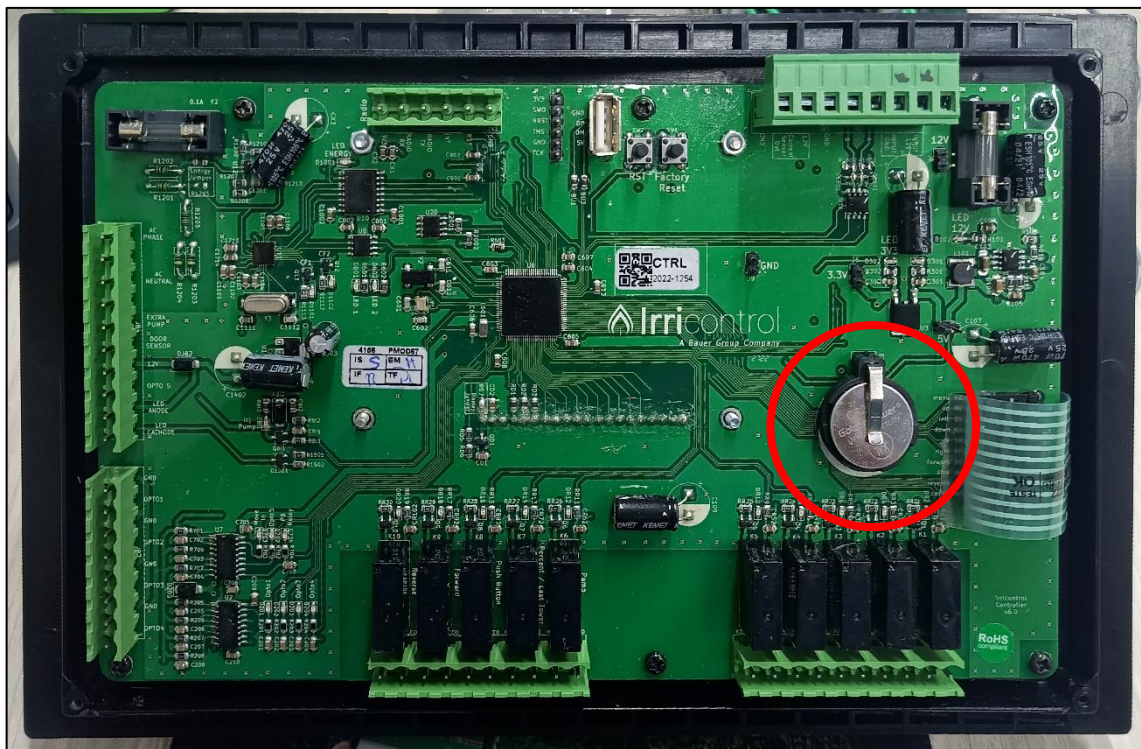

Figure 87 - Battery Position in the Controller.



The manufacturer recommends replacing the CR2032 3V battery every 2 years. However, Irricontrol advises checking its condition periodically, such as during the off-season or whenever system maintenance is performed.



Irricontrol is not responsible for malfunctions or additional costs resulting from operating the equipment with a weak or discharged CR2032 3V battery.

13.5.2. Cleaning the Interior of the Equipment

The inside of the equipment must remain free of dust, moisture, and debris to prevent damage to internal components, avoid short circuits, and extend its service life. Use a soft, dry cloth to remove dirt, and avoid applying chemical products, water jets, or metallic objects.



The frequency of this procedure should be determined based on the local conditions where the pivot is installed (level of exposure to dirt) and the availability of suitable personnel for the task.



It is recommended that the equipment cleaning also be checked whenever any on-site interaction with the cabinet is performed.

13.5.3. Checking the Silica Gel

All Irricontrol modules are supplied with silica gel inside, responsible for absorbing internal moisture and preventing condensation and damage to electronic components.

Therefore, always keep the silica gel inside the equipment. In addition, periodically check whether it is still active and replace it as necessary to ensure continued moisture absorption.



The frequency of this procedure must be established according to the local conditions where the equipment is installed (level of exposure to moisture and condensation). It may also be performed whenever system maintenance is carried out.

13.5.4. Checking the Seals

To prevent the entry of moisture, dirt, animals, or other impurities that could damage the equipment, it is important to ensure that the cabinet is properly sealed.

For this reason, whenever the cabinet is opened, check the closure of the external door and ensure that all cable glands are correctly secured.

13.5.5. Other Irrigation System Maintenance

It is important to perform all pre-established maintenance and adjustments for the irrigation system according to the pivot manufacturer's instructions.



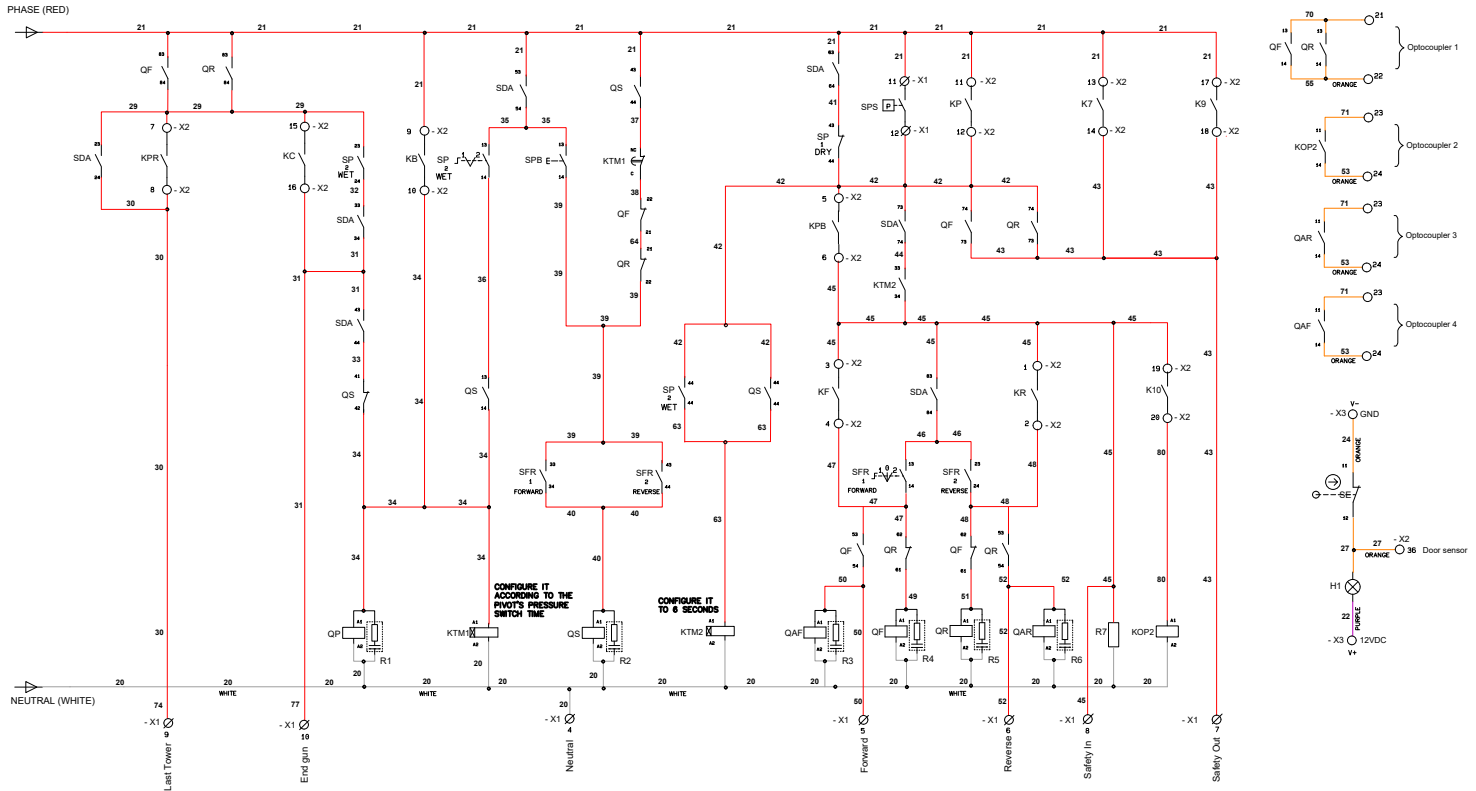
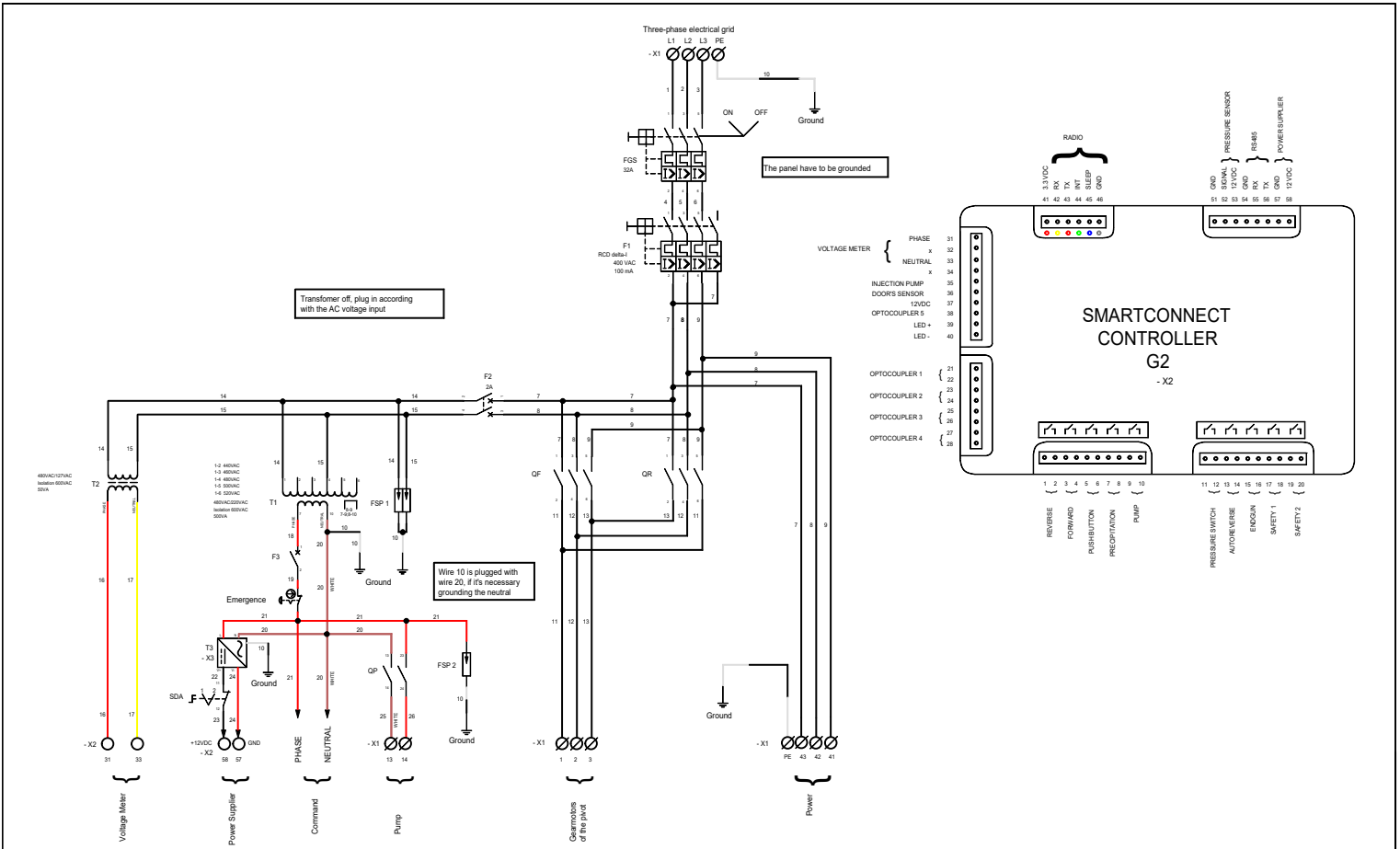

SUBTITLE	
F1 - CIRCUIT BREAKER 1 - RCD	QP - PUMP CONTACTOR
F2 - CIRCUIT BREAKER 2	QS - START CONTACTOR
F3 - CIRCUIT BREAKER 3	QAR - AUTOREVERSE REVERSE CONTACTOR
F4 - CIRCUIT BREAKER 4	QAF - AUTOREVERSE FORWARD CONTACTOR
F5S - GENERAL SWITCH	QF - FORWARD CONTACTOR
F5R - SURGE PROTECTION DEVICE	QR - REVERSE CONTACTOR
H1 - LIGHT FIXTURE 1	R1 - RC ELEMENT 1
K7 - AUTOREVERSE RELAY	R2 - RC ELEMENT 2
KF - FORWARD RELAY	R3 - RC ELEMENT 3
KB - PUMP RELAY	R4 - RC ELEMENT 4
KC - ENDGUN RELAY	R5 - RC ELEMENT 5
KP - PRESSURE SWITCH RELAY	SDA - DIGITAL/ANALOGIC SWITCH
KPB - PUSH BUTTON RELAY	SE - END SWITCH
KPR - PRECIPITATION RELAY	SFR - FORWARD/REVERSE SWITCH
KR - REVERSE RELAY	SP - PUMP SWITCH
KTM1 - TIME RELAY 1	SPB - PUSH BUTTON
KTM2 - TIME RELAY 2	SPS - PRESSURE SWITCH
OP1 - OPTOCOUPLER 1	T1 - TRANSFORMER 1
OP2 - OPTOCOUPLER 2	T2 - TRANSFORMER 2
OP3 - OPTOCOUPLER 3	T3 - 12VDC POWER SUPPLIER
OP4 - OPTOCOUPLER 4	PE - PANEL

WIRE COLORS / VOLTAGE	
(BLACK)	480 VAC
(GREEN/YELLOW)	GROUND
(RED)	220 VAC
(WHITE)	NEUTRAL (220 VAC)
(RED)	110 VAC
(YELLOW)	NEUTRAL (110VAC)
(PURPLE)	12 VDC
(ORANGE)	5VDC
(ORANGE)	END

* X1 PLUG IN THE PANEL BORNES TERMINAL
 * X2 PLUG IN THE SMARTCONNECT CONTROLLER
 * X3 PLUG IN THE 12VDC POWER SUPPLIER (T3)
 * X4 PLUG IN THE PANEL GROUND BORNES TERMINAL
 * WIRE (PE - PANEL) SHOULD BE CONNECTED ON THE GROUND OF THE PANEL.

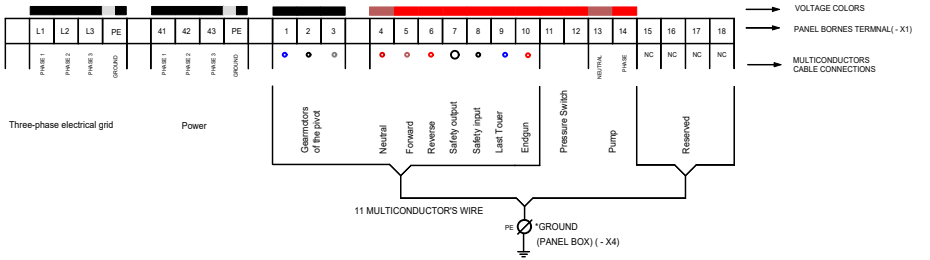

SmartConnect G2 Panel Electric Circuit	
Page revision:	5.7
Last correction:	30/11/2025
Constructor:	Rafael Granate Carociero
Approved by:	Luiz Alberto Roque



Irricontrol
A BAUER GROUP COMPANY